

Modeling and Analysis of Hybrid Shock Absorber for Military Vehicle Suspension

Harus Laksana Guntur¹, Wiwiek Hendrowati¹ and Tidy Budiarto²

¹Dynamic System and Vibration Laboratory, Department of Mechanical Engineering, Institut Teknologi Sepuluh Nopember (ITS), Surabaya, Indonesia

²Graduated Department of Mechanical Engineering, Institut Teknologi Sepuluh Nopember (ITS), Surabaya, Indonesia

email:haruslg@me.its.ac.id

Keywords: Hybrid suspension, regenerative shock absorber, regeneration of vibrational energy, vibration energy harvesting.

Abstract. This paper deals with the design, modeling and analysis of a hybrid shock absorber for vehicle suspension. A specific design of frictional-electromagnetic-regenerative shock absorber is proposed. The hybrid shock absorber consists of the proposed frictional-electromagnetic-regenerative shock absorber assembled in parallel with a conventional-viscous shock absorber. The concept of hybrid shock absorber is proposed due to the following advantages: the regenerative shock absorber will recover some wasted vibration energy from the suspension into electrical energy to support the need for electrical energy of the vehicle, while the viscous shock absorber maintains the performance of suspension closed to its original suspension. The vehicle suspension system dynamic was mathematically modeled for three different types of suspension: 1). Conventional suspension using viscous shock absorber; 2). Hybrid suspension using combination of 50% frictional-electromagnetic-regenerative shock absorber and 50% viscous shock absorber; and 3). Full regenerative suspension using 100% frictional-electromagnetic-regenerative shock absorber. In this research, 6 wheels military vehicle (APC: Armour Personal Carrier) is chosen as the model due to the high possibility of applying regenerative suspension to the military/off road vehicle. Based on the mathematical models, performances of the vehicle suspension and the regenerated power from regenerative shock absorber (RSA) were simulated. The results were compared between the three types of suspension and discussed.

Introduction

Only 10-16% of the fuel energy is used to drive the car to overcome the resistance from road friction and air drag. One important loss is the dissipation of vibration energy by shock absorber of the vehicle suspension due to road irregularity, vehicle acceleration and deceleration [1].

Sudaet *et al* [2] investigated a self powered active suspension control system, in which one motor is used to generate electricity and another motor is used to control the vibration. Nakano *et al* [3] also investigated the self-power vibration control using a single motor, in which a variable resistor, a charging capacitor and relay switches were used to control the motor force to follow the desired skyhook damping force. Okada *et al* [4] proposed an active-regenerative control for suspension, in which energy is regenerated at high speed motion, and active control is used to provide damping at low speed when the regenerative voltage lower than the battery voltage. Paulides *et al* [5] and Gysen *et al* [6] designed an electromagnetic regenerative suspension by modifying the shock absorber using permanent magnet and coil. Gupa *et al* [7] and Zuo [8] implemented an electromagnetic regenerative suspension in the vehicle suspension and investigated the performance experimentally.

Regenerative shock absorber can regenerate wasted vibrational energy into electrical energy. However, substituting conventional viscous shock absorber into frictional regenerative shock absorber will influence the performance of suspension system, as frictional shock absorber uses dry

friction damping. So this research deals with the design, modeling and analysis of hybrid proposed a concept of hybrid shock absorber which consists of a frictional-electromagnetic-regenerative shock absorber assembled in parallel with a conventional-viscous shock absorber. The concept of hybrid shock absorber is proposed due to the following advantages: the regenerative shock absorber will recover some wasted vibration energy from the suspension into electrical energy to support the need for electrical energy of the vehicle, while the viscous shock absorber maintains the performance of suspension closed to its original suspension. A specific design of frictional-electromagnetic-regenerative shock absorber is proposed. The vehicle suspension system dynamic was mathematically modeled for three different types of suspension: 1). Conventional suspension using viscous shock absorber; 2). Hybrid suspension using combination of 50% frictional-electromagnetic-regenerative shock absorber and 50% viscous shock absorber; and 3). Full regenerative suspension using 100% frictional-electromagnetic-regenerative shock absorber. Based on the mathematical models, performances of the vehicle suspension and the regenerated power from regenerative shock absorber were simulated, and the results were reported and discussed.

Design and Modelling of the Vehicle System

This section elaborates the structure of frictional regenerative shock absorber using electromagnetic generator, the mathematical modeling of the vehicle system dynamic for three different types of suspension: 1). Conventional suspension using viscous shock absorber; 2). Hybrid suspension using combination of 50% frictional-electromagnetic-regenerative shock absorber and 50% viscous shock absorber; and 3). Full regenerative suspension using 100% frictional-electromagnetic-regenerative shock absorber, and the state variable equation of the vehicle system dynamic.

Mathematical Model and State Variable Form of the Vehicle System

Mostly developed regenerative shock absorbers are frictional regenerative shock absorber. In principle frictional regenerative shock absorber uses gear transmission, which is dry friction damping and electromagnetic-electricity generator. We proposed a structure of frictional regenerative shock absorber (RSA) which can regenerate electricity from two directions of vibrational motion. All the existing frictional regenerative shock absorber developed by the previous researchers can regenerate electricity from only one direction of vibrational motion. So this proposed structure can capture vibrational energy twice than the previous structure. Figure 1 shows the structure of the proposed frictional regenerative shock absorber (RSA). The working principle of the proposed RSA is converting the oscillating vertical motion (vertically translational vibration) into one way rotational motion of the electromagnetic generator. One way bearing is used in pinion gear 1 to produce one direction of motion.

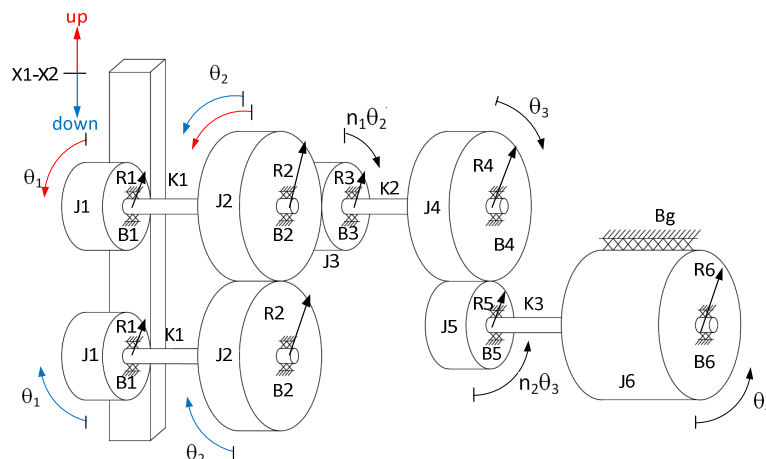

Fig.1 The structure and mathematical model of frictional-electromagnetic-regenerative shock absorber (RSA).

As shown by the red line, upward motion of the rack will be transmitted into one direction of clock-wise rotational motion by the upper pinion gear 1. And as shown by the blue line, downward motion of the rack will be transmitted into one direction of counter clock-wise rotational motion by the lower pinion gear one. And then these rotational motion will be transmitted into one direction of counter clock-wise rotational motion of the electricity generator, as shown by the black line. Body 6 is the electricity generator of the RSA. Figure 2 shows the physical model of the vehicle and Fig.3 shows the mathematical model of vehicle with conventional shock absorber, hybrid shock absorber and full regenerative shock absorber. Using Newton’s second law of motion, the equations of motion of sprung and un-sprung are obtained as shown in Eq.1 to Eq.8.

$$F_{c1} = \frac{J_1}{R_1^2} (\ddot{x}_1 - \ddot{x}_2) + \frac{k_1}{R_1} \left(\frac{x_1 - x_2}{R_1} - \theta_2 \right) + \frac{B_1}{R_1} \dot{\theta}_1 \tag{1}$$

$$J_2 \ddot{\theta}_2 - k_1 \left(\frac{x_1 - x_2}{R_1} - \theta_2 \right) + B_2 \dot{\theta}_2 + F_{c2} R_2 = 0 \tag{2}$$

$$F_{c2} = \frac{J_3 R_2}{R_3^2} \ddot{\theta}_2 + \frac{B_3 R_2}{R_3^2} \dot{\theta}_2 + \frac{k_2}{R_3} \left(\frac{R_2}{R_3} \theta_2 - \theta_3 \right) \tag{3}$$

$$J_4 \ddot{\theta}_3 - k_2 \left(\frac{R_2}{R_3} \theta_2 - \theta_3 \right) + B_4 \dot{\theta}_3 + F_{c3} R_4 = 0 \tag{4}$$

$$F_{c3} = \frac{J_5 R_4}{R_5^2} \ddot{\theta}_3 + \frac{B_5 R_4}{R_5^2} \dot{\theta}_3 + \frac{k_3}{R_5} \left(\frac{R_4}{R_5} \theta_3 - \theta_4 \right) \tag{5}$$

$$J_6 \ddot{\theta}_4 - k_3 \left(\frac{R_4}{R_5} \theta_3 - \theta_4 \right) + (B_g + B_6) \dot{\theta}_4 = 0 \tag{6}$$

$$m_w \ddot{x}_1 - c_w (\dot{y} - \dot{x}_1) - k_w (y - x_1) + c_v (\dot{x}_1 - \dot{x}_2) + k_v (x_1 - x_2) + F_{c1} = 0 \tag{7}$$

$$m_v \ddot{x}_2 - c_v (\dot{x}_1 - \dot{x}_2) + k_v (x_1 - x_2) - F_{c1} = 0 \tag{8}$$

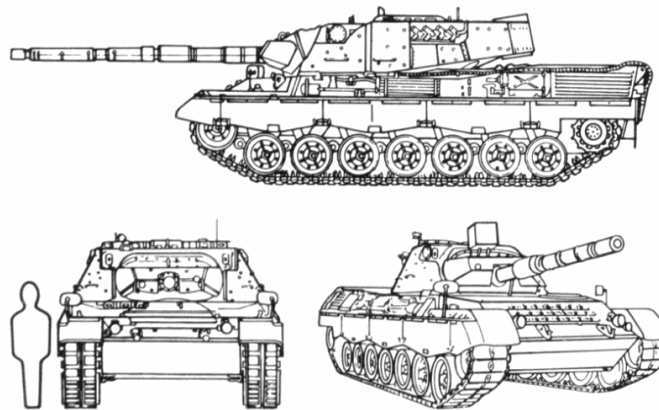

Fig.2 Physical model of the military vehicle

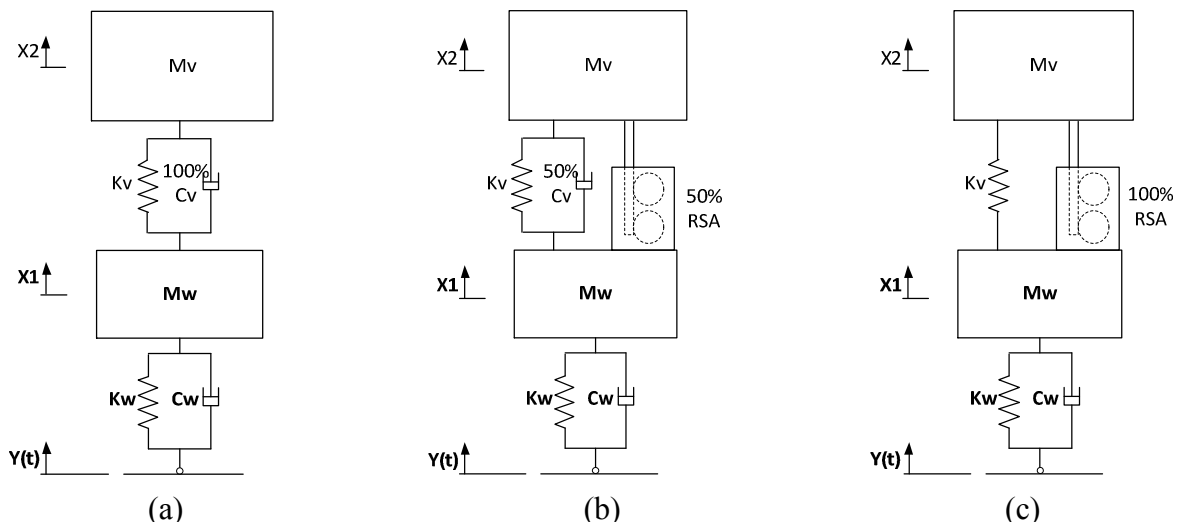

Fig.3 Mathematical model of vehicle with (a) Conventional shock absorber, (b) Hybrid shock absorber, (c) Full RSA.

Table 1 Parameters used in the simulation

Parameters	Symbol (unit)	Value
Total mass	m_v (kg)	17 000
Wheel mass	m_w (kg)	315
Number of wheel	N_w	6
Suspension spring stiffness	k_v (N.m ⁻¹)	$4,40 \times 10^5$
Tyre compliance	k_w (N.m ⁻¹)	$1,25 \times 10^6$
Suspension damping	c_v (N.s.m ⁻¹)	$1,25 \times 10^4$
Tyre damping	c_w (N.s.m ⁻¹)	2860

In this research, we use 6 wheels military vehicle (Transportpanzer Fuchs APC) as the model for simulation due to the high possibility of applying regenerative suspension to the military/off road vehicle. Table 1 shows the parameters of 6 wheels military vehicle (Transportpanzer Fuchs APC) used for the simulation.

Results and Discussion

Vehicle response to step excitation

Figure 4, 5 and 6 show the vehicle body displacement, velocity and accelerations of three different types of suspension subjected to step excitation. The red line indicates response of the conventional suspension using viscous shock absorber (without RSA). The hybrid suspension using combination of 50% frictional-electromagnetic-regenerative shock absorber and 50% viscous shock absorber is indicated by the blue line (50% RSA).

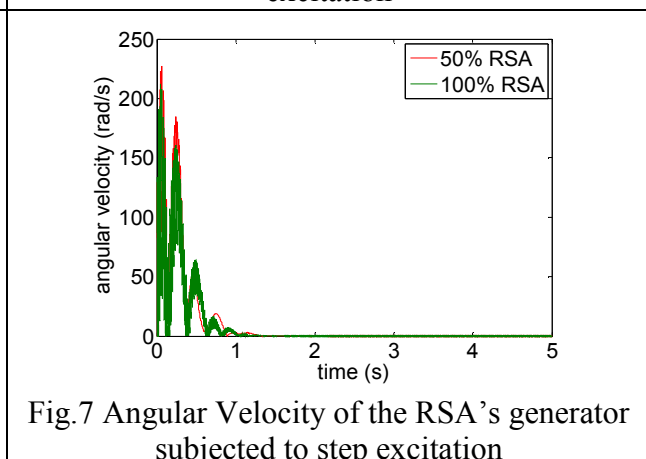
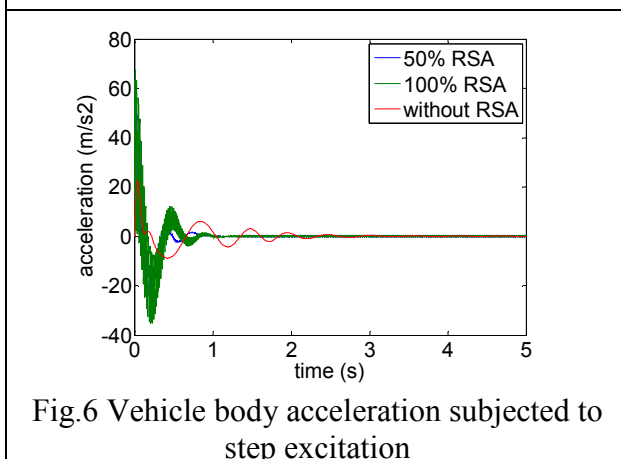
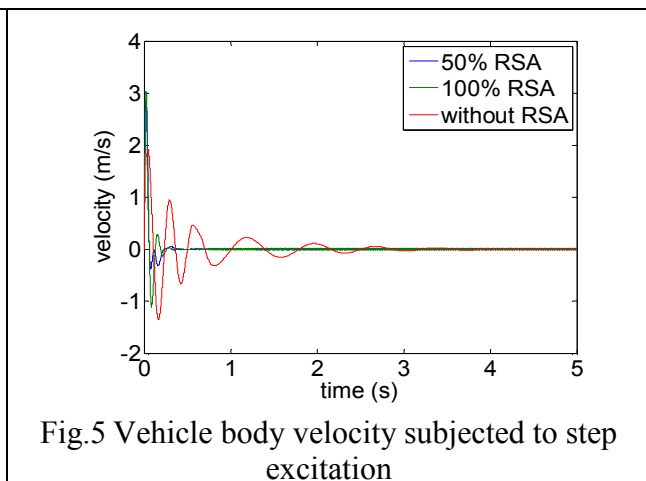
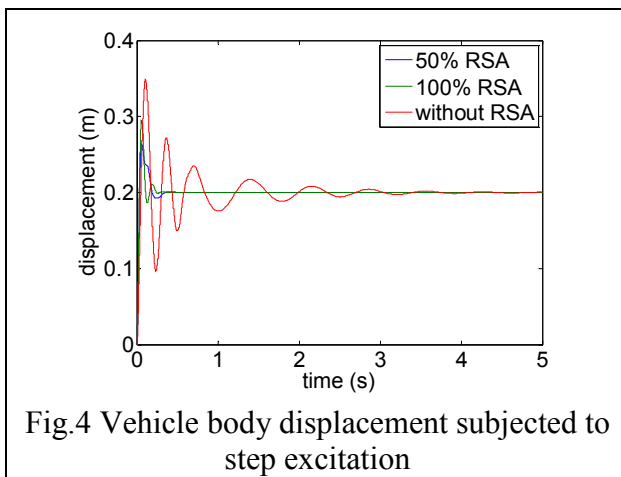

The full regenerative suspension using 100% frictional-electromagnetic-regenerative shock absorber is indicated by the green line (100% RSA). The figures show the transient responses of the vehicle. The results indicated that mounting RSA increase the vehicle damping constant. Figure 7 shows the transient response of the angular velocity of the RSA's electric generator subjected to step excitation. The result show that the difference in the angular velocity of the RSA's electric generator between the hybrid system (50% RSA) and full regenerative system (100% RSA) is very small, where the angular velocity of the generator indicates the generated voltage from the generator.

Vehicle Response to Harmonic Excitation

Figure 8, 9 and 10 show the vehicle body displacement, velocity and accelerations of three different types of suspension subjected to sinusoidal excitation for vehicle speed of 20km/h, road profile wave length of 6 m and amplitude of 0.2 m. The figures show the steady state responses of the vehiclesubjected to sinusoidal excitation for vehicle speed of 20km/h. The steady state responses show that at low speed, mounting RSA, both hybrid 50% RSA or full regenerative 100% RSA), do not influence the performance of the suspension.

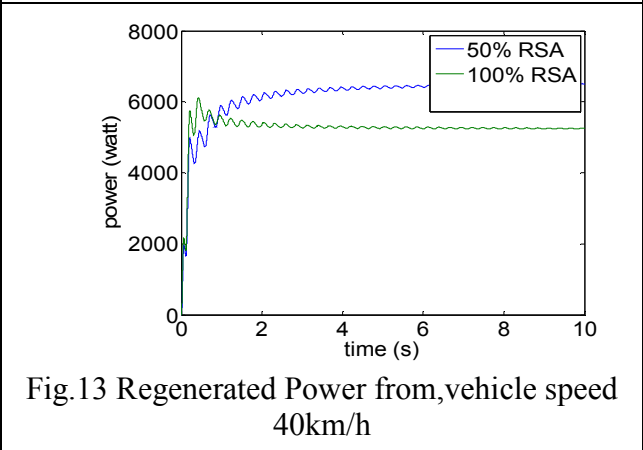
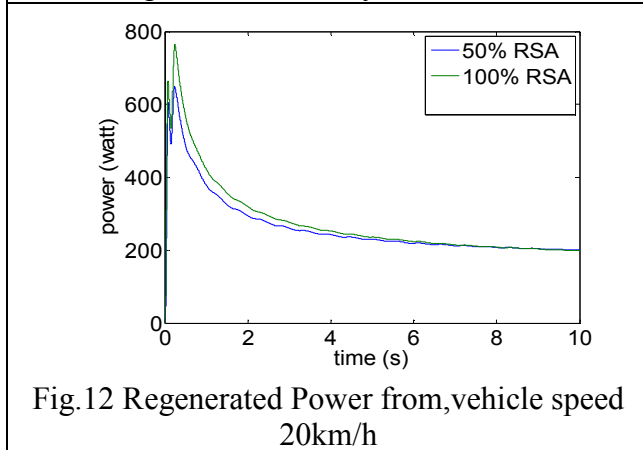
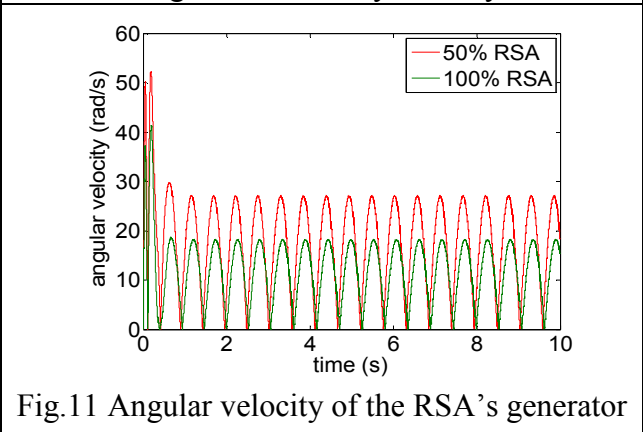
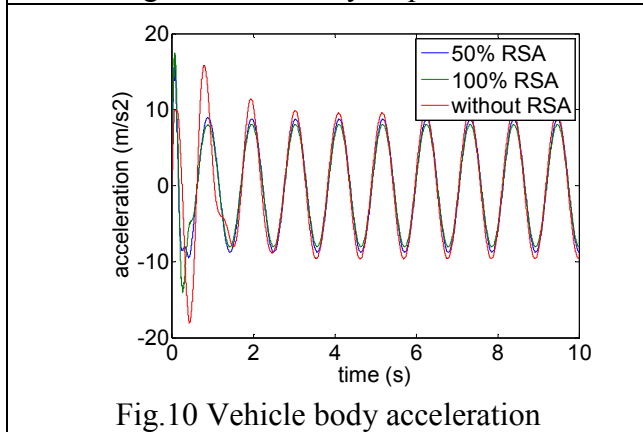
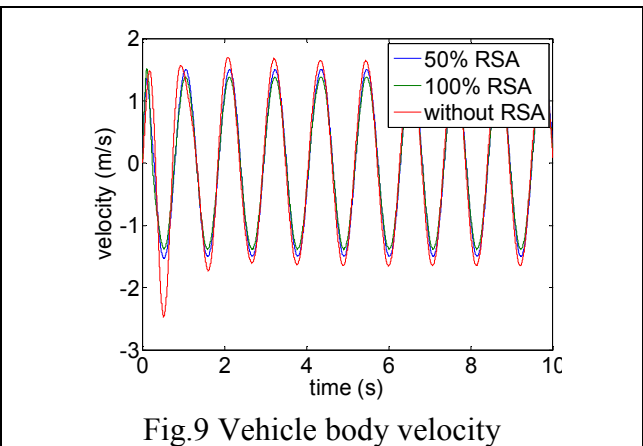
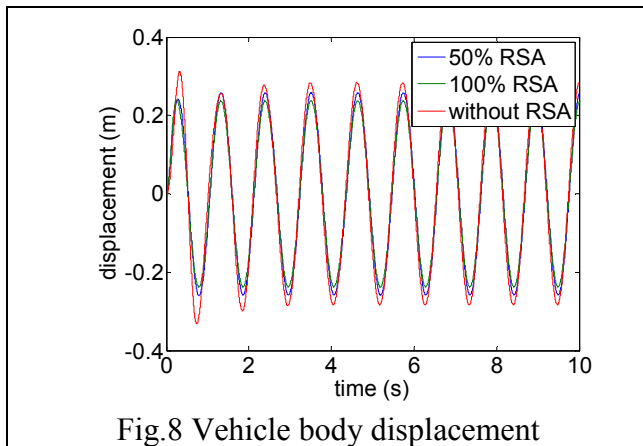

Figure 11 shows the steady state response of the angular velocity of the RSA's electricity generator subjected to sinusoidal excitation for vehicle speed of 20km/h. It is seen that hybrid system (50% RSA) produce 40% higher angular speed of the RSA's electricity generator than full regenerative system (100% RSA), which means higher output voltage.

Regenerated Power

Figure 12 and 13 show the steady state-generated power from the RSA subjected to harmonic/sinusoidal excitation for vehicle speed of 20 km/h dan 40 km/h, respectively. The results show that both full regenerative system (100% RSA) and hybrid system (50% RSA) regenerate the same power at low speed, 20 km/h. However, at higher speed, the hybrid system (50% RSA) can regenerate power of 25% higher than the full regenerative system (100% RSA). This result indicates that the proposed concept of hybrid suspension using combination of 50% frictional-electromagnetic-regenerative shock absorber and 50% viscous shock absorber can regenerate more power than full regenerative suspension using 100% frictional-electromagnetic-regenerative shock absorber. Furthermore, the hybrid suspension has another advantage as compared with full regenerative system, i.e. in case the regenerative shock absorber fail to work, the viscous conventional shock absorber still can work. This can not be fulfilled by the full regenerative suspension.

Summary

The proposed concept of hybrid suspension using combination of 50% regenerative shock absorber and 50% viscous shock absorber was mathematically modeled and numerically simulated. Its performance was compared to the conventional suspension using viscous shock absorber and the full regenerative suspension using 100% regenerative shock absorber. Six wheels military vehicle (Transportpanzer Fuchs APC) was chosen as the model for simulation. The results show that both hybrid suspension and full regenerative suspension increase the damping coefficient of the suspension due to inertia losses from the gear system in the regenerative shock absorber. However, it is confirmed that in the operating speed of 20 km/h ($\omega = 5.8$ rad/s) to (60 km/h ($\omega = 17.4$ rad/s)), the regenerative shock absorber of hybrid suspension generates higher power than that of full regenerative suspension. Where the phase lag shows no significant difference between hybrid and full regenerative.

References

- [1] M. V. Melosi, The automobile and the environment in American history, Automobile in American Life and Society, (Dearborn: University of Michigan Press), (2004).
- [2] Y. Suda and T. Shiba, New hybrid suspension system with active control and energy regeneration, Vehicle System Dynamic Supplement, Vol. 25, pp. 641-654, (1996).
- [3] K. Nakano, Y. Suda and S. Nakadai, "Self-powered active vibration control using a single electric actuator," *Journal of Sound Vibration*, Vol. 260, pp. 213-235, (2003).
- [4] Y. Okada, H. Harada and K. Suzuki, "Active and regenerative control of an electrodynamic-type suspension," *JSME Int J. Series C*, Vol. 40, pp. 272-278, (1997).
- [5] B. L. J. Gysen, J. L. G. Janssen, J. J. H. Paulides, and E. A. Lomonova, "Design aspects of an active electromagnetic suspension system for automotive applications," *IEEE Trans. Ind. Appl.*, Vol 45, no 5, pp. 1589-1597, (2009).
- [6] A. Gupta, J. A. Jendrzejczyk, T. M. Mulcahy and J. R. Hull, "Design of electromagnetic shock absorber," *Int. J. Mech. Mater. Des.*, In press, (2007). doi: 10.1007/s10999-007-9031-5.
- [7] L. Zuo, B. Scully, J. Shestani and Y. Zhou, "Design and characterization of an electromagnetic energy harvester for vehicle suspensions," *Smart Mater. Struct.*, IOP Publishing, Vol. 19, 045003(10pp), (2010). doi:10.1088/0964-1726/19/4/045003.

Advances in Applied Mechanics and Materials

10.4028/www.scientific.net/AMM.493

Modeling and Analysis of Hybrid Shock Absorber for Military Vehicle Suspension

10.4028/www.scientific.net/AMM.493.315