



BACHELOR THESIS & COLLOQUIUM - ME 184841

On-Bottom Stability of Offshore Pipeline Study Case at PGN Gas Pipeline Ujung Pangkah PSC Based On DNVGL-RP-F109

AKHBAR BUDDY AL AFGHAN
NRP 04211541000023

SUPERVISOR:

Prof. Dr. Ketut Buda Artana, ST.,M.Sc
Dr. Eng. Yeyes Mulyadi, S.T., M.Sc.

DOUBLE DEGREE PROGRAM
DEPARTMENT OF MARINE ENGINEERING
FACULTY OF MARINE TECHNOLOGY
INSTITUT TEKNOLOGI SEPULUH NOPEMBER
SURABAYA
2019

“This page intentionally left blank”



TUGAS AKHIR - ME 184841

On-Bottom Stability Pipeline Bawah Laut Studi Kasus pada Pipeline Gas PGN Ujung Pangkajene Berdasarkan DNVGL-RP-F109

**AKHBAR BUDDY AL AFGHAN
NRP 04211541000023**

DOSEN PEMBIMBING:

**Prof. Dr. Ketut Buda Artana, ST.,M.Sc
Dr. Eng. Yeyes Mulyadi, S.T., M.Sc.**

**DEPARTEMEN TEKNIK SISTEM PERKAPALAN
FAKULTAS TEKNOLOGI KELAUTAN
INSTITUT TEKNOLOGI SEPULUH NOPEMBER
SURABAYA
2019**

“Halaman ini sengaja dikosongkan”

APPROVAL FORM

ON-BOTTOM STABILITY OF OFFSHORE PIPELINE STUDY CASE AT PGN GAS PIPELINE UJUNG PANGKAH PSC BASED ON DNVGL- RP F-109

BACHELOR THESIS

Submitted to Comply One of the Requirement to Obtain a Bachelor Engineering
Degree

On

Laboratory of Marine Realiability and Safety (RAMS)
Bachelor Program Departement of Marine Engineering
Faculty of Marine Technology
Sepuluh Nopember Institute of Technology

Prepared by

Akhbar Buddy Al Afghan
NRP. 04211541000023

Approved by

Academic Supervisor

Prof. Dr. Ketut Buda Artana, ST., M.Sc.
NIP. 196510301991021001



Dr. Eng. Yeyes Mulyadi, S.T., M.Sc.
NIP. 197401271999031002



“This page is intentionaly left blank”

APPROVAL FORM

ON-BOTTOM STABILITY OF OFFSHORE PIPELINE STUDY CASE AT PGN GAS PIPELINE UJUNG PANGKAH PSC BASED ON DNVGL- RP F-109

BACHELOR THESIS

Submitted to Comply One of the Requirement to Obtain a Bachelor Engineering
Degree

On

Laboratory of Marine Realiability and Safety (RAMS)
Bachelor Program Departement of Marine Engineering
Faculty of Marine Technology
Sepuluh Nopember Institute of Technology

Prepared by

Akhbar Buddy Al Afghan
NRP. 04211541000023

Approved by

Representative of Wismar in Indonesia

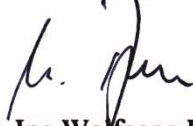

Dr.-Ing Wolfgang Busse

“This page is intentionally left blank”

APPROVAL FORM

ON-BOTTOM STABILITY OF OFFSHORE PIPELINE STUDY CASE AT PGN GAS PIPELINE UJUNG PANGKAH PSC BASED ON DNVGL- RP F-109

BACHELOR THESIS

Submitted to Comply One of the Requirement to Obtain a Bachelor Engineering
Degree

On

Laboratory of Marine Realiability and Safety (RAMS)
Bachelor Program Departemen of Marine Engineering
Faculty of Marine Technology
Sepuluh Nopember Institute of Technology

Prepared by

Akhbar Buddy Al Afghan

NRP. 0421154100023



Approved by
Head of Marine Engineering Departement

Dr. Eng. Muhammad Badrus Zaman S.T., M.T.
NIP. 197708022008011007

“This page is intentionaly left blank”

DECLARATION OF HONOR

I hereby who signed below declar that:

This final project has written and developed independently without any plagiarism act. All content and ideas draw directly from internal and external sources are indicated such as cited sources, literatures and other professional sources.

Name : Akhbar Buddy Al Afghan

Student Number : 04211541000023

Final Project : On-Bottom Stability Of Offshore Pipeline Study Case At
PGN Gas Pipeline Ujung Pangkah PSC Based On
DNVGL-RP-F109

Departement : Marine Engineering

If there is plagiarism act in the future, I will fully responsible and receive the penalty given by Its according to the regulation applied.

Surabaya, July 2019

Akhbar Buddy Al Afghan

“This page is intentionally left blank”

ON-BOTTOM STABILITY OF OFFSHORE PIPELINE STUDY CASE AT PGN GAS PIPELINE UJUNG PANGKAH PSC BASED ON DNVGL- RP F-109

Name : Akhbar Buddy Al Afghan
Student Number : 042115101023
Departement : Marine Engineering
Supervisor : Prof. Dr. Ketut Buda Artana, ST., M.Sc.
Dr. Eng. Yeyes Mulyadi, S.T., M.Sc.

ABSTRACT

In the oil and gas industry, there is a pipeline system that is used to channel the results from upstream exploration to the receiving place. The pipeline can stretch both on land and at sea. In the following cases, the subsea gas pipeline is the object of analysis. Requires accurate analysis to ensure the pipeline can operate properly. There are many influences on the influence of subsea pipelines, especially on hydrodynamic loads received by pipes which can cause movement in pipes, soil erosion, etc. Its phenomenon that occurs due to hydrodynamic loads can cause the risk of deformation and fracture in the pipe. The author wants to analyze the on-bottom stability of PGN gas pipeline in Ujung Pangkah. Therefore an accurate calculation of the stability of the pipe is needed so that the pipe does not experience movement and is not bent or broken during operation. In DNV RP F-109 there are three methods that can be used to calculate the on-bottom stability of subsea pipelines. The method used is the absolute static lateral stability method because the method has the requirement that the pipeline force must be able to withstand the maximum force from hydrodynamic loads, also find the vertical stability. The result of vertical stability of PGN gas pipeline in zone I, zone II, zone III, zone IV, zone V, zone VI, zone VII, and zone VIII are same with value 1.5125 qualify the safety factor of lateral stability, ≥ 1.1 . The lateral stability of PGN gas pipeline in shore is 3.782, zone I 4.048, zone II 3.315, zone III 3.36, zone IV 2.723, zone V 1.29, are qualify the safety factor of lateral stability, ≥ 1.1 . Zone VI 0.941, zone VII 1.021, and zone VIII 1.059 are not qualify the safety factor of lateral stability, ≥ 1.1 .

Keyword : On Bottom Stability, Hydrodynamic Loads, Absolute Static Lateral Stability Method

“This page is intentionally left blank”

ON-BOTTOM STABILITY PIPELINE BAWAH LAUT STUDI KASUS PADA PIPELINE GAS PGN UJUNG PANGKAH PSC BERDASARKAN DNVGL-RP-F109

Name : Akhbar Buddy Al Afghan
Student Number : 042115101023
Departement : Marine Engineering
Supervisor : Prof. Dr. Ketut Buda Artana, ST., M.Sc.
Dr. Eng. Yeyes Mulyadi, S.T., M.Sc.

ABSTRAK

Dalam industri minyak dan gas, ada pipeline yang digunakan untuk menyalurkan hasil dari eksplorasi hulu ke stasiun penerimaan. Pipa terbentang baik di darat maupun di laut. Pada kasus berikut, pipa gas bawah laut merupakan objek analisis. Dibutuhkan analisis yang akurat untuk memastikan pipa dapat beroperasi dengan baik. Ada banyak pengaruh pada pengaruh pipa bawah laut, terutama pada gaya hidrodinamik yang diterima oleh pipa yang dapat menyebabkan pergerakan pipa, erosi tanah, dll. Fenomena yang terjadi akibat beban hidrodinamik dapat menyebabkan risiko deformasi dan patah pada pipa. Penulis ingin menganalisis stabilitas pipa gas PGN bawah laut di Ujung Pangkah. Oleh karena itu diperlukan perhitungan stabilitas pipa yang akurat agar pipa tidak mengalami pergerakan dan tidak bengkok atau patah selama operasi. Dalam DNVGL-RP-F109 ada tiga metode yang dapat digunakan untuk menghitung stabilitas bawah laut pipa. Metode yang digunakan adalah metode stabilitas lateral statis absolut karena metode ini memiliki persyaratan bahwa gaya pipa harus mampu menahan gaya maksimum dari beban hidrodinamik, juga menemukan stabilitas vertikal. Hasil stabilitas vertikal pipa gas PGN di zona I, zona II, zona III, zona IV, zona V, zona VI, zona VII, dan zona VIII sama dengan nilai 1.5125 yang memenuhi syarat faktor keamanan stabilitas vertikal, ≥ 1.1 . Stabilitas lateral pipa gas PGN di pantai adalah 3,782, zona I 4,048, zona II 3,315, zona III 3,36, zona IV 2,723, zona V 1,29, memenuhi syarat faktor keamanan stabilitas lateral, ≥ 1.1 . Zona VI 0,941, zona VII 1,021, dan zona VIII 1,059 tidak memenuhi syarat faktor keamanan stabilitas lateral, ≥ 1.1 .

Kata kunci : Stabilitas Bawah Laut, Gaya Hidrodinamik, Metode Stabilitas Lateral Statis Absolut

“This page is intentionally left blank”

PREFACE

All the gratitude toward Almighty Allah for all the blessing and gifts so that the author can complete final project with title of “On-Bottom Stability Of Offshore Pipeline Study Case At Pgn Gas Pipeline Ujung Pangkah PSC Based On DNVGL-RP-F-109” in order to fulfill the requirements to obtaining the bachelor degree program at Marine Engineering Department, Faculty of Marine Technology, Sepuluh Nopember Institute of Technology.

During the accomplishment of this final project, author so that the author is able to complete this very well. All thanks are delivered.

1. Prof. Dr. Ketut Buda Artana, ST., M.Sc. as Supervisor I of author’s thesis and Dr. Eng. Yeyes Mulyadi, S.T., M.Sc. as Supervisor II of author’s thesis for the assistance and advices during the completion of final project.
2. Dr. Eng. Muhammad Badrus Zaman, S.T., M.T. as the Head of Marine Engineering Departement.
3. Budiarso and Wiwik Fatmawati as the beloved parents for the countless support and prayers for the author’s success as well as.
4. Megananda Arum C. P. as the beloved girl’s for the prayer and support mentally the thesis completion.
5. Kontrasol peoples, for all supports and prayers during the completion of the thesis.
6. Kolega ngopi, for all supports and prayers during the completion of the thesis.
7. Marine Engineering student fellow intake 2015, Salvage’15 for all great support during college time and this final year.
8. RAMS Laboratory members, for all support, prayers, and helps during authors’s completion on the thesis.
9. MOM Laboratory members, for all support, prayers, and helps during authors’s completion on the thesis.
10. And other parties whom author’s can’t mention all but very meaningful for author’s.

Because this work is also far from a perfect work, author will really appreciated for every advice, suggestion and idea from all parties for this bachelor thesis correction and improvement in the future. By the completion of this bachelor thesis, author hopes this thesis will be helpful and beneficial for other parties who are going to conduct the similar research.

Surabaya, July 2019

Akhbar Buddy Al Afghan

“This page is intentionally left blank”

TABLE OF CONTENT

Contents	
APPROVAL FORM	i
DECLARATION OF HONOR.....	vii
ABSTRACT.....	ix
ABSTRAK.....	xi
PREFACE.....	xiii
TABLE OF CONTENT	xv
LIST OF FIGURE(S).....	xvii
CHAPTER I.....	1
1.1 Background.....	1
1.2 Statements of Problems.....	3
1.3 Objectives	3
1.4 Constraints	3
CHAPTER II.....	5
2.1 Literature Study	5
2.2 Theory	6
2.2.1 Pipeline	6
2.2.2 Wave Loads	6
2.2.3 Wave Theory.....	7
2.2.4 Current Speed Calculation	10
2.2.5 Fluid Flow Aroud Cylinder Pipe.....	10
2.2.6 Hydrodynamic Forces	11
2.2.7 Calculation of soil friction calibration factor	13
2.2.8 Bouyancy	14
2.2.9 Submerged Wieght of Pipe	14
2.2.10 Reynolds Number	15
2.2.11 Vertical Stability	16
2.2.12 Dynamic Lateral Static Stability Method.....	16
2.2.13 General Lateral Static Stability Method.....	17
2.2.14 Absolute Lateral Static Stability Method.....	17

CHAPTER III.....	19
3.1 Methodology Flow Chart.....	19
3.2 Description of Methodology Flowchart.....	21
CHAPTER IV.....	25
4.1.1 Data Collection.....	25
4.1.1 The Data of Pipe.....	25
4.1.2 Data of Operation Condition	26
4.1.3 Environmental Data.....	26
4.2 Analysis of Environmental Data.....	27
4.2.1 Theory of Wave.....	27
4.2.2 Length of Wave and Acceleration of Wave	28
4.2.2.1 Stokes 2 Wave Theory.....	28
4.2.2.2 Stokes 3 Wave Theory.....	29
4.2.3 Calculation of Velocity of Water Particles on Pipeline.....	30
4.2.4 Calculation of Soil Friction Calibration Factor	31
4.2.5 Calculation of Hydrodynamic Forces.....	32
4.2.6 Modelling and Validation of Hydrodynamics forces	34
4.2.7 Calculation Of Minimum Submerged Weight Pipe.....	34
4.3 Pipe property calculation.....	35
4.4 Calculation of Lateral And Vertical Stability Analysis.....	36
4.5 Analysys of Stability of Pipe on Different Types of Soil.....	37
4.6 Analysys of Stability of Pipe in Different Thickness of Concrete	39
4.7 Analysis of pipeline movements when due to hydrodynamic forces	41
CHAPTER V.....	43
5.1 Conclusion.....	43
5.2 Suggestion	44
REFERENCES	46

LIST OF FIGURE(S)	
Picture 1.1 Pipeline maps.....	1
Picture 1.2 Deformation of pipe.....	2
Figure 1.3 Free span correction data.....	2
Picture 2.1 Pipeline in infrastructure facilities.....	6
Picture 2.2 Example of Wave Profile.....	7
Picture 2.3 Chart of Region of Validity of Wave Theories.....	8
Picture 2.4 Aquatic Classification According to Wavelength and Depth.....	10
Picture 2.5 Skecth of Force.....	10
Picture 2.12 Hydrodynamics Load on pipe.....	11
Picture 2.7 Calibration Factor, F_w as Function of 'K and M.....	13
Picture 2.8 Transverse Pipe Cutting.....	14
Picture 3.1 Chart of Region of Validity of Wave Theories.....	21
Picture 4.1 Chart of Region of Validity of Wave Theories.....	28
Picture 4.2 Calibration Factor, F_w as Function of 'K and M.....	32
Picture 4.3 Calibration Factor, F_w as Function of 'K and M.....	32
Picture 4.4 Simulation of Hydrodynamics Force on Pipeline.....	34
Picture 4.5 Corelation of Types of Soil and Vertical Stability	38
Picture 4.6 Corelation of Types Of Soil and Lateral Stability	38
Picture 4.7 Corelation of Thickness of Concrete and Vertical Stability	39
Picture 4.8 Corelation of Thickness of Concrete and Vertical Stability	40
Picture 4.8 Deformation of Pipeline Based on Simulation	41

“This page is intentionaly left blank”

LIST OF TABLE(S)

Table 2.1 sea deep criteria	9
Table 2.2 Detemination of soil friction calibration factor.....	13
Table 2.3 Recommended Coefficient of Hydrodynamics.....	16
Table 4.1 Pipeline Data.....	25
Table 4.2 Pipeline Data.....	26
Table 4.3 The Data of wave.....	26
Table 4.4 The data of current.....	27
Table 4.5 Data of Soil Conditions.....	27
Table 4.6 Table of Wave Theory Calculation.....	28
Table 4.7 Table of Wave Theory Calculation.....	29
Table 4. 8 Table of Wave Theory Calculation.....	30
Table 4.9 Table of Speed of Water Particles Calculation	30
Table 4.10 Table of Speed of Water Particles Calculation	31
Table 4.11 Table of Friction calibration factor	31
Table 4.12 Table of Hidrodynamic Forces Calculation.....	33
Table 4.13 Table of Submerged Weight Requirements Calculation.....	35
Table 4.14 Table of Lateral Stability Calculation.....	36
Table 4.15 Table of Vertical Stability Calculation	37
Table 4.16 Table of Stability of Pipe on Different Types of Soil Calculation.....	37
Table 4.17 Table of Stability of Pipe on Different Thickness of Concrete Calculation	39
Table 4.14 Table of Lateral Stability Calculation.....	64

“This page is intentionaly left blank”

CHAPTER I INTRODUCTION

1.1 Background

Oil and gas are energy sources which are currently still widely used in various sectors. In recent years in Indonesia, the use of gas as a source of energy began to be widely used in many sectors such as industry, commercial, household, etc. Therefore, the fulfilment of gas needs must adjust to the existing demand. Besides meeting the needs, there are important factors in transporting gas both in the transmission and distribution process using a lot of pipeline technology. Pipelines can stretch from land (onshore) to offshore. Offshore pipelines, better known as subsea pipes, are a transportation technology used to transport hydrocarbon products such as crude oil, high-pressure natural gas, and relatively low condensate. The fluid carried by subsea pipelines in large quantities and long distances and passed through the sea or offshore pipeline is one of the popular modes of transportation of natural gas and petroleum because in addition to being fast, it is also economical. Underwater pipes can work 24 hours a day, 365 days a year for the life of a pipe that can reach 30 years or even more (Soegiono, 2007).

When determining pipeline routes, it is not uncommon to find cases where pipeline routes to be determined to meet different environmental conditions. The different environmental conditions can be waves, current velocities, soil types, etc. which affect the installation and operation of subsea pipelines. Offshore gas pipeline PGN which transmits gas from sources in Pangkah PSC to OFP Saka Indonesia in Gresik stretching under the Java sea is a pipeline that passes the sea lane.

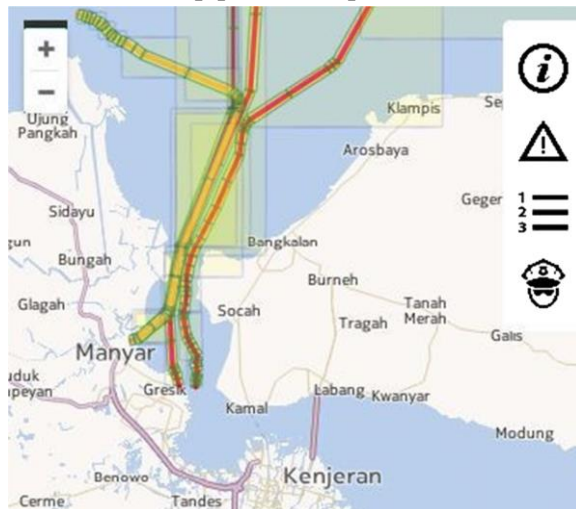

Picture 1.1 Pipeline maps
(source: umar,2017)

The stretch of pipe with depth on the seabed with varying waves and velocities makes the gas pipe obtain various forces from ocean waves which cause the pipe to move. The movement of the pipe can cause a risk of deflection and even

the risk of fracture due to continuous hydrodynamic forces regarding the pipe. Not only by the gas pipe wave at the bottom of the sea it also depends on the strength of the soil, in this case the soil friction force which affects the external forces of the pipe. The type of soil can have a high friction force that opposes the external forces of the pipe to maintain the position of the pipe itself. But when the ground that becomes pipe support collapses due to the pipe load it can also cause the pipe to run the risk of being deflected and even broken. Also the impact of hydrodynamic forces in the form of deformation and fracture can occur due to several things such as pipe shifting, scouring, free span, etc.

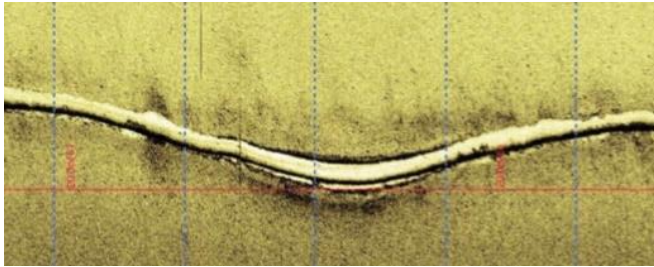

Picture 1.2 Deformation of pipe
(source:)

This phenomenon can occur at any time because the pipe is continuously exposed to dynamic hydro forces. local buckling phenomenon which is a change in the shape of a pipe (dents) often occurs and can cause holes and even faults. While the pipe shift and scouring that forms the free span that occurs can cause deformation and fracture in the pipe. This can damage the underwater pipeline that operates to deliver gas. as in the following example.

Year	Client	Project	Scope
2015	Shell / Technip	Malikai	Free span correction for 10" and 8" pipelines
2014	Petronas	Ketapang	Free span correction for 110 km x 12" pipeline
2013	Leighton Offshore	Balongan	12" Pipeline X-Ray field to Balongan pipeline
2013	Hess Carigali / Emas	Belida	FPSO Flexible Riser Supports
2013	Pertamina EP / Timas	Parigi	Pipeline Hot tap and Gas Diversion
2013	PTTEP / L&T	Zawtika Phase 1A	2 x 18" pipelines (10km each)
2012	Conoco Phillips/Timas	Tembang	8" x 150m tie-in spool from Tembang Tee to T8 Well
2012	Conoco Phillips/Timas	Bawal	14" pipeline x 40 km and tie-ins

Figure 1.3 Free span correction data
(source: Offshore Construction data)

The table above is data from a subsea pipeline construction and maintenance company, namely Offshore Construction Specialist which shows free span during the pipeline operation. this free span event can cause serious damage to the pipe if left untreated. as well as local buckling and pipe shifting. From the data above, the hydrodynamics force can caused damage to the pipeline i.e free span happened after the soil of sea bed eroded by hydrodynamic forces. To prevent the risk of bending and fracturing of the offshore gas pipeline, the calculation of on-bottom stability in the pipeline is carried out to determine the hydrodynamic pressure of the ocean wave and the strength of the contour to support the pipe. the weight of the pipe along with coating according to the conditions in the Java sea environment in accordance with the standard calculation on DNV RP F-109. From the results of calculations and analysis, it is also proven through modelling using ANSYS software to validate the results of calculations. So with the analysis of on-bottom stability in the gas pipeline, it is expected to reduce the risk of deflection and fracture in PGN's offshore gas pipelines.

1.2 Statements of Problems

1. How to define and Calculate the hydrodynamic forces which influent to stability of subsea pipe?
2. How to calculate the total submergedweight and submergedweight requeriment of subsea pipeline case in PGN gas pipeline in Ujung Pangkah of subsea pipeline?
3. How to calculate lateral and vertical stability based on DNVGL-RP-F-109 case in PGN gas pipeline in Ujung Pangkah with variation of soil soft clay, clay, and silty sand?

1.3 Objectives

1. To know the external forces acting on the pipe and their influence on pipe difficulties.
2. To know the total submergedweight submergedweight requeriment of subsea pipeline case in PGN gas pipeline in Ujung Pangkah of subsea pipeline.
3. To know the lateral and vertical subsea pipes with variations in soft clay soil, clay and muddy sand case in PGN gas pipeline in Ujung Pangkah.

1.4 Constraints

1. The case study used is the installation of a gas pipeline offshore PT PGN Saka Energi.
2. The standard used is DNV RP F109.
3. The calculated pipe condition is the pipe at the time of operating conditions.
4. The soil is assumed by various types of soil, namely soft clay, clay, and homogeneous silty sand along the pipe.
5. The condition of the land along the pipe is assumed to be flat
6. The analysis of pipe stability used is absolute lateral static stability method.
7. The scouring effect is ignored.

“This page is intentionally left blank”

CHAPTER II LITERATURE STUDY

2.1 Literature Study

Natural gas is one of the energy sources used in the world as an energy source other than coal and petroleum. Unlike petroleum, gas is an energy source that is more environmentally friendly than petroleum. From upstream sources, gas is transported through a pipeline system which is a pipe with a long stretch to drain gas fluid to the receiving station. Only from the gas receiving station is distributed to the customer for use.

The term pipeline is defined as a stretch of fluid pipe with a very long distance. Commodities that are often transported are water, natural gas, crude oil, and other petroleum processing products (Liu, Henry, 2003). Pipelines are used in a variety of purposes, one of which is as a trunk line that is transporting oil and/or gas from production facilities to land (Mousselli, 1981). Usually, these pipes are stretched long through the underwater (onshore) and onshore lines. With a long stretch and to distribute large amounts of gas fluid or earth oil, strong and durable material is needed. Pipes usually use steel material coated with an anti-rust coating. Pipes are also protected by using concrete coating, burial, cover (sand, gravel, mattress) and various other mechanical protection to prevent the pipe from the risk of danger that can occur. In addition, government regulation in the form of a minister of mining and energy number 300.k was born. /38.pel/1997 article 13 paragraph 3 which states that the distribution pipes held at sea must fulfil the provisions that have been made, namely as follows:

- a. In the case of the depth of the seabed of less than 13 meters, the pipe must be planted at least 2 (two) meters below the seabed (seabed) and equipped with ballast so that the pipe does not shift or move.
- b. In the case of the depth of the seabed 13 (thirteen) meters or more, the pipe can be placed on the seabed (held) and equipped with a ballast system so that the pipe does not shift or move.
- c. After completing the deployment of the pipe in the area where the pipe is located, the area where the pipe is located must be equipped with Suggestions to Assist Shipping Navigation (SBNP) in accordance with the provisions of the applicable laws and regulations.

Clinton (2015) has calculated the stability of subsea pipelines by knowing local buckling so that the stability of subsea pipelines can meet vertical and lateral safety factors by referring to the DNV RP E109 method.

2.2 Theory

2.2.1 Pipeline

Offshore / offshore oil and gas exploration requires advanced technology because the location of oil / gas reservoirs / sources is far from land and is located at

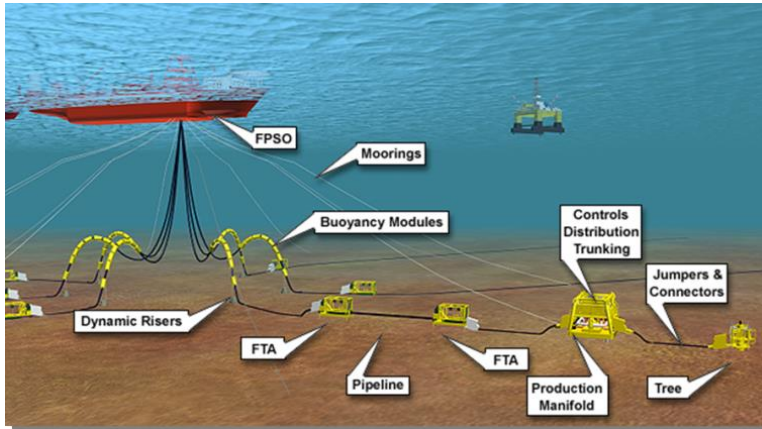

varying depths. Therefore, it requires infrastructure facilities to support the work, including offshore platforms (platforms), floating structures, and pipelines.

Picture 2.1 Pipeline in infrastructure facilities

(source: oceaneering)

Offshore Pipelines generally function to channel/transmit hydrocarbons in the form of liquid or gas from a reservoir or exploration facility located offshore. Because of the location of the reservoir that is inside the seabed, a pipeline is needed to transport it to the facility on land. Another term for the offshore pipeline is the subsea pipeline.

The size of the pipeline used is diverse, ranging from 8 "to 40". The distance travelled by the pipeline from reservoir to land varies, ranging from just a few kilometres to the longest currently reaching 1,200 kilometres (located in the North Sea, connecting Norway with Britain).

2.2.2 Wave Loads

Sea wave is formed because the sea surface is exposed to continuous gusts of wind. Waves absorb energy from the wind and instead emit energy for distribution. According to Indiyono (2004), wave loads are the largest burden caused by environmental burdens on offshore structures. Calculation of wave loads can be represented by calculation of wave force. The theory selection requirements for the calculation of wave force are based on the comparison between the structure diameter (D) and the wavelength (L) as follows,

$D / L > 1$ Wave force approaches pure reflection, the Morison equation is invalid

$D / L > 0.2$ Wave diffraction needs to be taken into account, the Morison equation is invalid

$D / L < 0.2$ Equation Morison valid. The theory used in calculating wave force (Indiyono, 2004)

2.2.3 Wave Theory

Wave is the factor that caused the pipeline moving from initial condition.

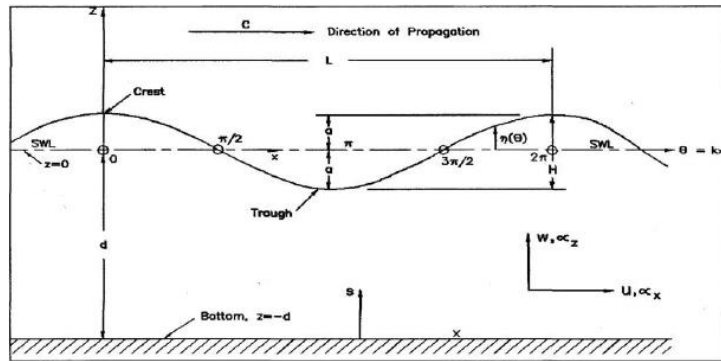

Picture 2.2 Example of Wave Profile
(source: Ekoefendi, 2011)

$$L = \frac{g T^2}{2\pi} \quad (1)$$

$$C = \frac{g T}{2\pi} \quad (2)$$

$$k = \frac{2\pi}{L} \quad (3)$$

$$y = \frac{H}{2} \quad (4)$$

$$s = d + y$$

With,

d = water deep (m)

H = height of wave (m)

L = Wave length with water deep estimation (m)

T = wave period (s)

k = wave number ,

y = wave coordinates above SWL

s = wave coordinates above seabed

By knowing the wavelength of deep waters, we can calculate the wavelength for waters with other depths. The results of the mathematical formulation are then adjusted to the Regional graph Application of Wave Theory Regions of Validity of Wave Theories, as shown in Figure 2.3 so that the wave theory that will be used can be known.

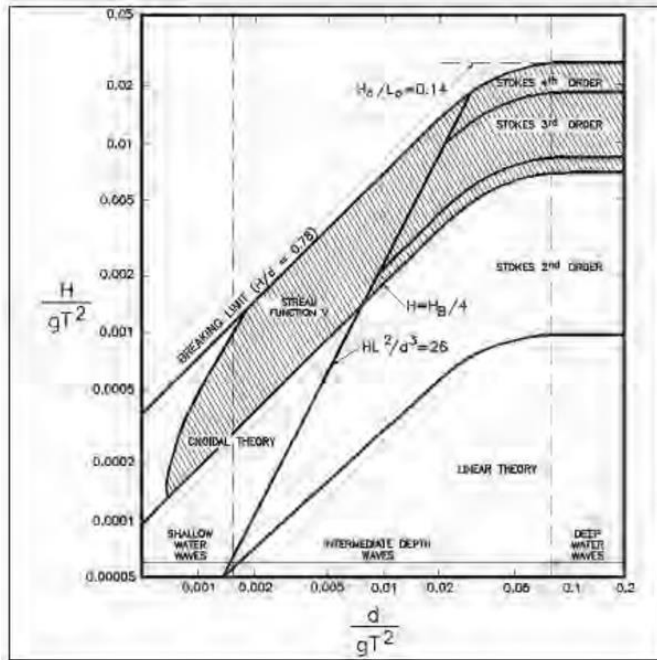

Picture 2.3 Chart of Region of Validity of Wave Theories
(source: Mousselli, 1981)

Wave theory that will be used in the design can be determined using mathematical formulations of linear wave theory (Mousselli, 1981). The formulations used are as follows:

$$\left[\frac{H}{gT^2} \right] \text{ dan } \left[\frac{d}{gT^2} \right] \quad (5)$$

With:

d = water deep (m)

H = height of wave (m)

T = wave period (s)

g = gravity (m/s^2)

2.2.2.1 2nd Stokes Orde Wave Theory

By knowing the wavelength of deep waters, we can calculate the wavelength for waters with other depths. The results of the mathematical formulation are then adjusted to the Regional graph Application of Wave Theory Regions of Validity of

Wave Theories, as shown in Figure 2.3 so that the wave theory that will be used can be known

Generally, waveforms in nature are very complex and difficult to describe mathematically because they are not linear, three-dimensional, and have a random shape (Triatmodjo, 1999). Determination of the applicable wave theory is based on parameters that are suitable for sea conditions. These parameters are in the form of wave height, period and depth of the sea observed. Stokes wave theory is a solution for waters that require a higher level of accuracy than linear wave theory. Stokes includes the expression of the potential velocity in the Laplace equation and the seabed boundary conditions. The coefficient of the series is a parameter increase that is associated with amplitude and wavelength.

The velocity equation and the acceleration of wave particles in the horizontal direction for the 2nd order stokes wave theory can be seen from the following equation (Triatmodjo, 1999):

- Horizontal Velocity

$$U = \frac{\pi H}{T} \frac{\cosh h}{\sinh h} \cos \theta + \frac{3}{4} \left(\frac{\pi H}{L} \right) \frac{\pi H}{T} \frac{\cosh^2 ks}{\sinh^2 kd} \cos 2\theta \quad (6)$$

- Horizontal Acceleration

$$\frac{u}{t} = \frac{2\pi^2 H}{T} \frac{\cosh ks}{\sinh h kd} \cos \theta + \frac{3\pi^2 H}{T^2} \left(\frac{\pi H}{L} \right) \frac{\cosh^2 ks}{\sinh^4 kd} \cos 2\theta \quad (7)$$

With:

d = water deep (m)

H = height of wave (m)

L = Wave length with water deep estimation (m)

T = wave period (s)

k = wave number

y = wave coordinates above SWL

s = wave coordinates above seabed

g = gravity (m/s^2)

Table 2.1 sea deep criteria

Approximation	Criteria	Wave length
Deep water	$d/L > 1/2$	$L = gT^2 / 2\pi$
Shallow water	$d/L < 1/20$	$L = T \sqrt{gd}$

With examples of wave profile images as shown in Figure 2.4 below:

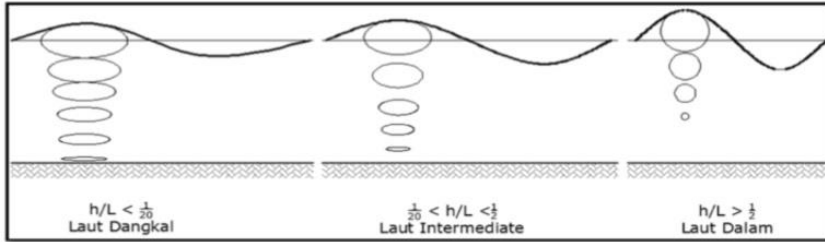

Picture 2.4 Aquatic Classification According to Wavelength and Depth
(source: Hafzhuddin, 2015)

2.2.4 Current Speed Calculation

The formula used to calculate the current velocity is (DNV E-305), as follows:

$$U_D = U_r \left[\frac{\left(1 - \frac{z_o}{D} \left(\ln \left(\frac{D}{z_o} + 1 \right) - 1 \right)}{\ln \left(\frac{z_r}{z_o} + 1 \right)} \right) \sin \theta_{curr}} \right] \quad (8)$$

U_D = average velocity over pipe diameter (m/s)

U_r = reference steady velocity (m/s)

z_o = bottom roughness parameter (m)

z_r = reference height above seabed (m)

d = diameter of pipeline (m)

2.2.5 Fluid Flow Aroud Cylinder Pipe

The selection of flow (flow) depends on the properties of local waves and into the waters (Bai, 2001). The flow around the cylinder will produce a resultant force on the surface of the cylinder, which is divided into two parts, namely the first force caused by pressure and the two forces caused by the roughness of Figure 2.8 in the direction of the resultant force.

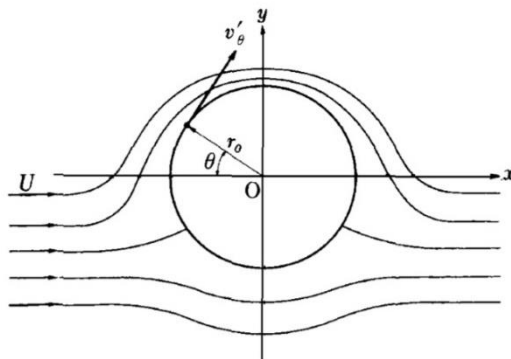

Picture 2.5 Skecth of Force
(source: octav, 2013)

Reduced velocity is the speed at which oscillations are due to vortex shedding (Guo, 2005). The existence of vortex shedding will result in a component of transverse force (cross flow) which is commonly called lifting force. The force on the cylinder due to the wave force depends on the Reynold number. Other influences, namely the shape of the object, exposure, turbulence and friction will cause changes in flow. When the flow has a low Reynold number ($Re < 40$) which will experience vortex shedding, the pressure distribution around the cylinder will experience periodic changes in the process. This will cause a force that is micro-metallic on the cylinder. The total pressure distribution can be obtained by integrating the force on the cylinder surface.

2.2.6 Hydrodynamic Forces

The stability of the subsea pipeline is influenced by hydrodynamic forces because of its presence in a moving fluid, namely seawater. The hydrodynamic style of the pipe includes the force of drag (drag force), inertia force (inertia force) and lift force (lift force). Hydrodynamic forces greatly influence the stability of the pipe structure.

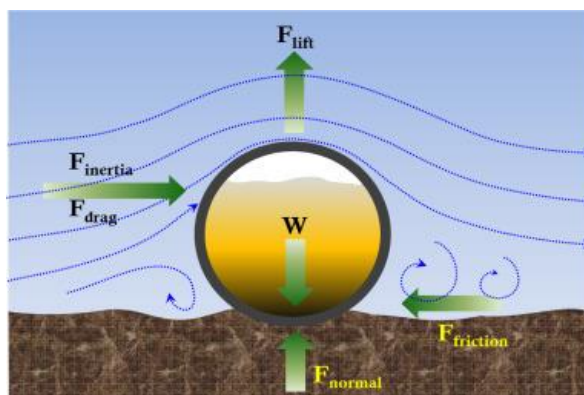

Picture 2.12 Hydrodynamics Load on pipe
(source: Clinton, 2015)

According to Det Norske Veritas RP-C205, your Environmental Conditions, Environmental Load, hydrodynamic forces can be formulated as follows:

- Drag force

Drag force occurs due to friction between the fluid in which there is a pipe environment with a pipe known as skin friction and the presence of vortices that occur behind the pipe. The drag force is greatly influenced by flow velocity, the value of the drag force can be obtained using the following formula.

$$F_D = 1/2 \rho C_D (U_s \cos\theta + U_c)^2 \quad (9)$$

With :

= drag force

ρ = density (kg/m³)

D = outside diameter include concrete (m)

CD = drag coefficient

- Inertia force

The inertia force is due to a period of fluid being transferred by the pipe. The value of inertia is affected by the acceleration of water particles. The value can be formulated as follows:

$$F_I = \rho CM \left[\frac{\pi D^2}{4} \right] \left(\frac{dU}{dt} \right) \quad (10)$$

With :

ρ = density (kg/m³)

D = outside diameter include concrete (m)

CM = inertia coefficient or mass coefficient

du/dt = current acceleration (m/s²)

- Lifting force

The lifting force is a hydrodynamic force in the vertical direction that occurs because there is a streamlined concentration of the pipe. The pipeline concentration occurs above the pipe cylinder which results in an upward lift in the pipe. When there is a narrow gap between cylinders and seabed, the streamlined concentration under the pipe cylinder will result in a negative lifting force downward. The magnitude of this lifting force can be formulated as follows:

$$FL = 1/2 \rho C_L (U_s \cos\theta + U_c)^2 \quad (11)$$

With :

ρ = density (kg/m³)

D = outside diameter include concrete (m)

U_e = particle effective velocity (m/s)

CL = lifting coefficient

- Friction Force

When an object located on a surface is given a horizontal direction, the reaction force will appear opposite the touch plane between the object and the surface. This style is generally called friction. Pipe structure under the sea also has friction force due to forces acting on the pipe structure. In subsea pipelines, friction is one factor in the stability of the pipe on the seabed. This friction force is influenced by the coefficient between the outer surface of the pipe and the surface of the sea floor. The magnitude of the friction coefficient is influenced by the type of pipe

material and the type of soil on the seabed where the pipe is located. The friction that occurs can be seen in the following figure 2.12.

The amount of friction can be calculated using the following equation:

$$F_R = \mu \cdot N \quad (12)$$

Where,

F_R = friction force (N/m)

μ = friction factor coefficient

N = normal force is the vertical force upward direction (N/m)

2.2.7 Calculation of soil friction calibration factor

the value of the soil friction calibration factor is used to calculate the submerged weight of the required pipe (W_{s_req}). the value of the factor is adjusted to the type of soil seabed and can be searched after finding the value of Carpenter Source (K) and wave velocity current ratio (M). The following table determines the friction calibration factor according to soil classification.

Table 2.2 Determination of soil friction calibration factor
(source: DNV RP-305)

Soil types	Friction calibration factor
Sand	0.7
Clay	Based on friction factor graph (DNV RP E305)

After finding the value of Keulegan Carpenter number (K) and wave velocity current ratio (M), the calibration factor value can be obtained with the following graph.

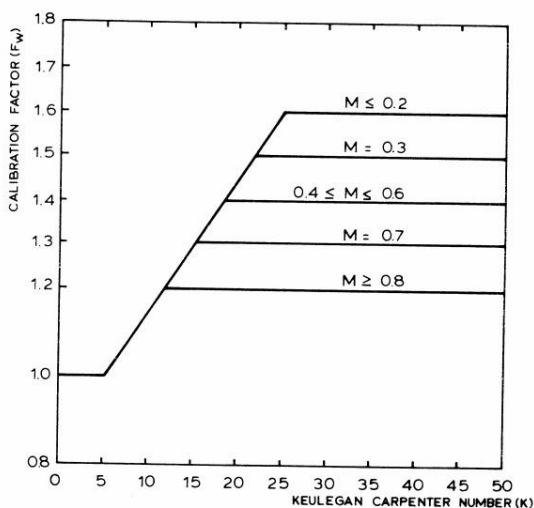

Picture 2.7 Calibration Factor, F_w as Function of 'K' and M
(source: DNV RP-305)

2.2.8 Bouyancy

As expressed in Archimedes' Law, that all objects immersed in a fluid have a buoyant force proportional to the weight of the fluid it transfers. Because the pressure at each point on the surface of the object is equivalent to the specific weight of the fluid and the depth, the total force acting on the left and right of the object becomes the same and can be ignored. Equilibrium horizontal direction force, $\sum F_x = 0$. As for the vertical direction, the magnitude of the force acting on the upper and lower objects is not as large, this is because the average depth of the upper surface of the object is smaller than the average depth of the surface the bottom of the object. This causes a large force to work towards the lower to be smaller than the large force acting towards the top. The large difference in this force is commonly known as the buoyancy (B) of liquid to matter. If the object is in equilibrium, then the upward force will be equal to the weight of the object downward. So, the magnitude of buoyancy force can be calculated using the formula:

$$B = \rho \times g \times V \quad (13)$$

Where,

B = buoyancy (N)

ρ = density of liquid matter (kg/m³)

g = gravity (m/s²)

2.2.9 Submerged Wieght of Pipe

The illustration of the cross section of a pipe is like Figure 2.5 below,

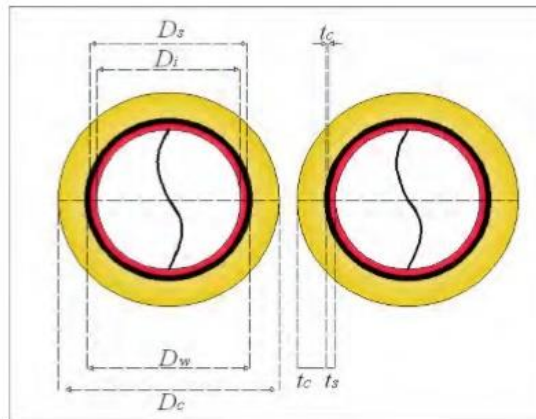

Picture 2.8 Transverse Pipe Cutting

(source: Asfatur, 2017)

Following formula below is the calculation formula for pipe submerged weight:

- Outside diameter of pipe

$$D = D_o + 2t_{cor} + 2t_c \quad (14)$$

- Inner diameter of pipe

$$D_i = D_o - 2t_{st} \quad (15)$$

• Weight steel (W_{st})

$$W_{st} = \frac{\pi}{4} \rho_{st} (D_o^2 - D_t^2) \quad (16)$$

• Weight corrotion (W_{corr})

$$W_{corr} = \frac{\pi}{4} \rho_{corr} [(D_o + 2 t_{corr})^2 - D_t^2] g \quad (17)$$

• Weight concrete (W_c)

$$W_c = \frac{\pi}{4} \rho_c [(D_o + 2 t_{corr} + 2t_c)^2 - (D_o + 2 t_{corr})^2] g \quad (18)$$

• Weight of contain (W_{cont})

$$W_{cont} = D_t^2 \rho_{cont} g \quad (19)$$

• Bouancy (B)

$$B = \frac{\pi}{4} \rho_w (D_o + 2 t_{corr} + 2t_c)^2 g \quad (20)$$

• Submerged Wieght of pipe

$$W_s = W_{st} + W_{corr} + W_c + W_{cont} - B \quad (21)$$

• Submerged weight requirement of pipe

$$W_s req = \left[\frac{(F_D + F_I) + \mu \cdot F_L}{\mu} \right] \cdot F_w \quad (22)$$

With,

D_o = outside diameter (m)

D_i = inside diameter (m)

D_w = wrap diameter (corrosin wrap) (m)

D_c = coating diameter (concrete coating) (m)

t_{st} = thickness of steel (m)

t_{corr} = thickness of corrotion coating, (m)

t_c = thickness of concrete, (m)

W_{st} = weight steel (N/m)

W_{corr} = weight corrotion coating (N/m)

W_c = weight concrete (N/m)

W_{cont} = weight contain (N/m)

W_s = submerged weight (N/m)

B = bouancy (N/m)

F_D = drag force (N/m)

F_I = inertia force (N/m)

F_L = lifting force (N/m)

μ = friction factor

F_w = calibration factor

$W_s req$ = submerged weight requirement (N/m)

2.2.10 Reynolds Number

The Reynold number indicates the form of the flow formed which is linear or turbulence. Reynold number is related to the resistance of an object. In searching

for the value of the Reynold number is a comparison between the inertia force (FD) and the viscous forces. The Reynold number itself is formulated as follows:

$$Re = \frac{Ue D}{\nu k} \quad (23)$$

With,

νk = kinematic viscosity of seawater (m²/s)

ue = particle effective velocity (m/s)

D = diameter of structure(m)

In its application, the reynold number to find the value of hydrodynamic forces can be used to determine the hydrodynamic coefficient used in calculating the hydrodynamic forces used in the cylinder structure. Determination of the hydrodynamic coefficient can be obtained from the table below.

Table 2.3 Recommended Coefficient of Hydrodynamics

(source: Mousselli, 1981)

Reynold Number (Re)	Hydrodynamic Coefficient		
	Cd	Cl	Ci
$Re < 5.0 \times 10^4$	1.3	1.5	2.0
$5.0 \times 10^4 < Re < 1.0 \times 10^5$	1.6	1.0	2.0
$1.0 \times 10^5 < Re < 2.5 \times 10^5$	$1.53 - \frac{Re}{5 \times 10^5}$	$1.2 - \frac{Re}{5 \times 10^5}$	2.0
$2.5 \times 10^5 < Re < 5.0 \times 10^5$	0.7	0.7	2.5
$Re > 5.0 \times 10^5$	0.7	0.7	1.5

2.2.11 Vertical Stability

Vertical stability is stability of pipe in vertical line in the seabed. Because of each things which in water has bouyancy force that same with the weight. So, to avoid pipe floating, the submerged weight of the pipeline shall meet the following criterion:

$$\gamma_w = \frac{b}{w_{s+b}} = \frac{\gamma_w}{s_g} \leq 1.0 \quad (24)$$

With,

γ_w = vertical Stability

b = bouyancy (N/m)

w_s = submerged weight of pipeline (N/m)

2.2.12 Dynamic Lateral Static Stability Method

DLS is the most comprehensive method for lateral pipe stability because a complete three-dimensional pipe simulation can be performed certain combinations of waves and currents in time domain analysis. Unfortunately, DLS has not been used much.

DLS requires a time domain simulation of the pipeline's dynamic response, including the behavior of the pipe structure, modeling of pipe–soil interaction, and the time variation of hydrodynamic loads.

2.2.13 General Lateral Static Stability Method

The General Lateral Static Stability method is a set of design figures and tables that are calibrated from numerical and experimental analyses. An allowable displacement in a design spectrum of oscillatory wave-induced velocities running perpendicular to the pipeline is normally adopted.

The design spectrum is characterised by spectrally derived characteristics U_s (oscillatory velocity), T_u (period) and the associated steady current velocity V . As a special case a “virtually stable” case is considered whereby the displacement is limited to about one half pipe diameter and is such that it does not reduce the soil resistance and the displacements do not increase no matter how long the sea-state is applied for.

2.2.14 Absolute Lateral Static Stability Method

There are several methods used to obtain the stability value of subsea pipelines, namely dynamic lateral method, generalized lateral method, and absolute lateral static method. In this study, the absolute lateral static method is used because it only calculates stability in normal conditions which calculates static stability based on lateral force static that meets the requirements for pipe resistance to be able to against motion to withstand maximum hydrodynamic loads.

$$\gamma_{SC} = \frac{(W_s - F_L) \cdot \mu}{F_D \cdot F_I} \geq 1.0 \quad (25)$$

With,

γ_{SC} = lateral Stability

W_s = submerged weight of pipeline (N/m)

F_D = drag force (N/m)

F_L = lift force (N/m)

F_I = inertia (N/m)

μ = friction factor

“This page is intentionally left blank”

CHAPTER III METHODOLOGY

3.1 Methodology Flow Chart

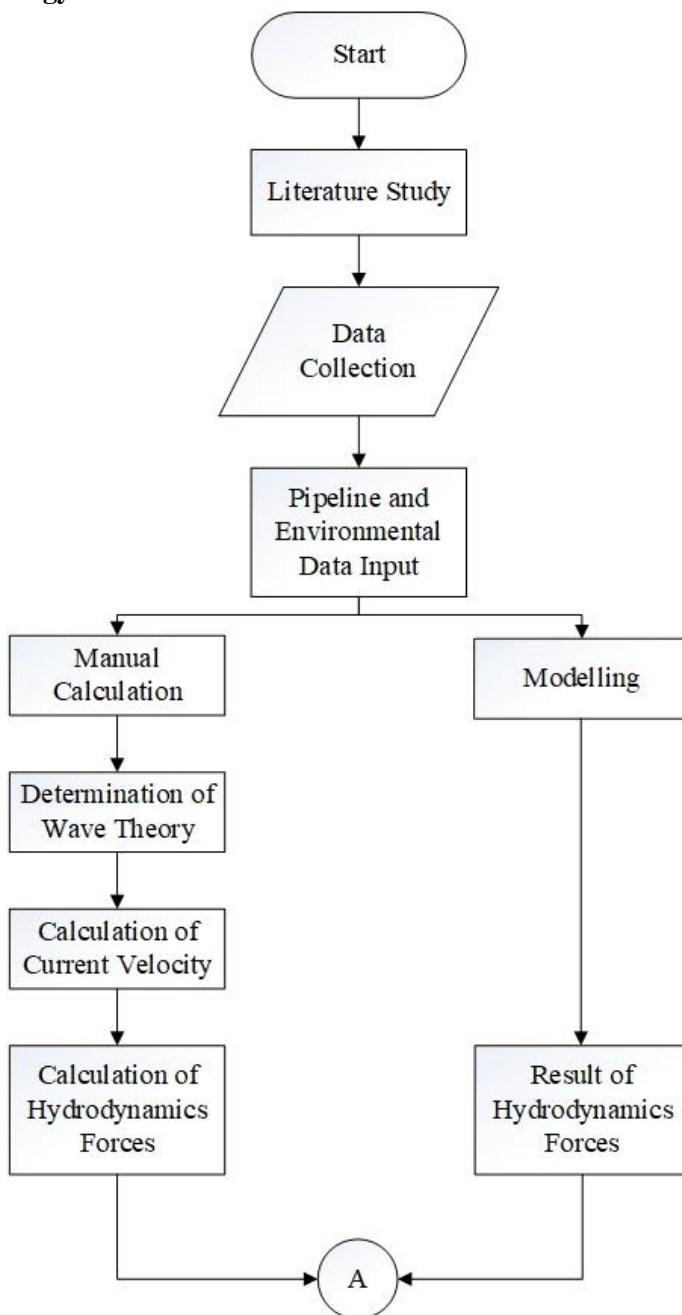

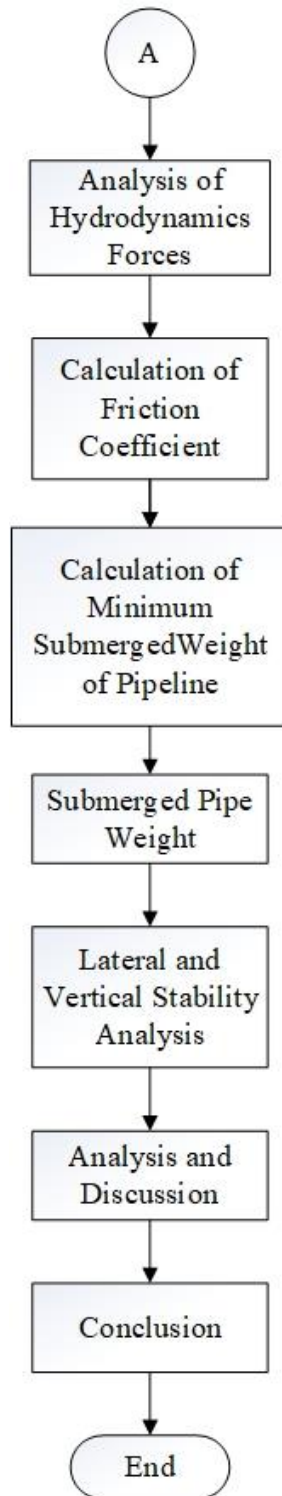

3.2 Description of Methodology Flowchart

Literature Study

Looking for final project support material to be carried out to complete the research conducted. The material sought is in accordance with the final assignment that is taken, which is about On Bottom Stability. Supporting materials include gas pipes, standards for pipelines, wave and current theory, hydrodynamics, soil mechanics theory, standard DNV RP F109, etc.

Data Collection

Data collection uses several methods, namely, literature study, observation, interviews, and data on the design and operation of PGN gas pipes, current and wave conditions in the pipeline environment and soil conditions.

Pipeline Environmental Data Input

Inputting the required pipe data is the type of outer diameter, wall thickness, steel density, corrosion coating density, concrete coating thickness, concrete coating density, content density as a pipe design parameter, and pipe operation.

Environmental data used in this study are seawater density, sea water depth, significant wave height, kinematic viscosity, significant wave period, current velocity, and gravitational acceleration.

Modelling

Using ANSYS, can know the pressure of pipe and the influent to the pipe.

Determination Of Wave Theory

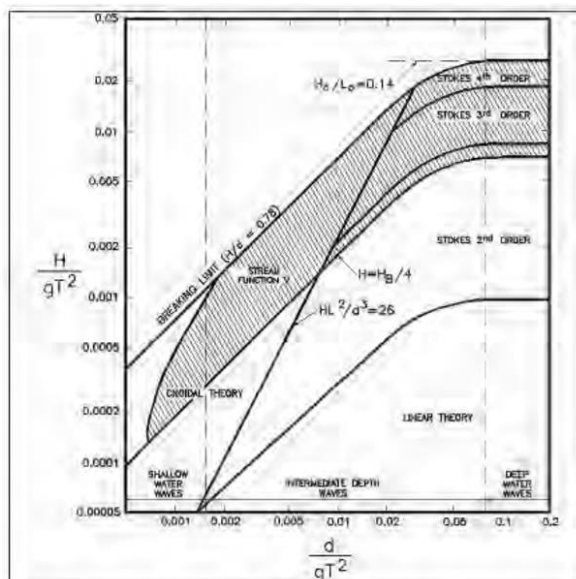

Picture 3.1 Chart of Region of Validity of Wave Theories
(source: Mousselli, 1981)

Determination of wave theory is based on the needs of the theory that will be used in this study. Using Chart of Region of Validity of Wave Theories can have the wave theory that used.

The wave theory used in this study is the second order stokes wave theory which will produce the speed and acceleration of water particles.

Determination of Current Velocity

To get the current velocity, it is get by using a formula in accordance with DNV RP F-109.

Calculation of Hydrodynamics Forces

Before calculating hydrodynamic forces (FD, F1, and FL) first determine the values of hydrodynamic coefficient (drag coefficient, inertia coefficient, and lift coefficient). To get the hydrodynamic coefficient the value of Reynold number, pipe roughness and keulegan-carpenter value are used.

Calculation of Soil Friction Coefficient

For the friction calibration factor, it is adjusted to the type of soil friction. For clay soil types, the soil friction calibration factor was obtained, 0.7, while the sand soil type was adjusted by friction factor graph (DNV Rp. E305). The calibration factor value (Fw) is needed to calculate the weight of the sink pipe needed (Ws req). Calibration factor can be determined using the graph below, previously it has obtained the carpenter number (K) and current ratio values for wave velocity (M).

Calculation Of Submergedweight Pipe

Pipe property calculations include calculation of pipe outer diameter (D), steel weight in air (Wst), the weight of anti-corrossion in the air (Wcorr), the weight of concrete blanket in the air (Wc), pipe filler weight (Wcont) and buoyancy force (B).

After the pipe parameter data is obtained, then look for what is the value of the pipe submerged weight (Wsub) using the following formula $W_s = W_{st} + W_{corr} + W_c + W_{cont} - B$.

Calculation Of Minimum Weight Submerged Pipe

Minimum Weight Submerged Pipe is the minimum weight that must be met with pipes when in certain conditions. To get the value of the submerged pipe we use the formula in accordance with DNV RP F-109.

Lateral And Vertical Stability Analysis

To analyze the stability of the subsea pipeline, one of the analytical methods that can be used, namely in DNV Rp. 109 is the lateral static stability as a whole. The general equation of this method is

$$\gamma_{SC} = \frac{(W_s - FL) \cdot \mu}{FD \cdot F1} \geq 1.0$$

While the analysis of vertical arbitration using the following equation

$$\gamma w = \frac{b}{ws+b} = \frac{\gamma w}{sg} \leq 1.0$$

“This page is intentionally left blank”

CHAPTER IV DISCUSSION AND RESULT

4.1.1 Data Collection

The case study used in this study is the Saka Ujung Pangkah PGN subsea pipeline under operating conditions with a service period of 25 years. The pipe stretches from the Ujung Pangkah gas field to the Madura strait until it empties into the receiving station on the north coast of Gresik. Data presented includes material data and their dimensions and pipeline environment data (currents, waves, soil conditions, etc.). From these data can be obtained the initial calculation to determine the value of the current speed, hydronamic forces and calculate the pipe property. Below is the data needed to perform calculations in pipe stability analysis in the Ujung Pangkah gas pipe case study.

4.1.1 The Data of Pipe

Data on the type of material and pipe dimensions were obtained from the Saka Ujung Pangkah PGN gas pipe design data which included diameter, thickness, material, density, modulus of elasticity, and poisson ratio. External pipe coating data includes material, density, and thickness. All data can seen in the table 4.1 below.

Table 4.1 Pipeline Data
(source: UPD, 2005)

Parameter	Data	Unit
Outer Diameter	457	mm
Material	API 5 L X 65	
Wall Thickness	14.8	mm
SMYS	448	Mpa
Steel Density	7850	Kg/m3
Anti-corrosion coating thickness (Asphalt Enamel)	5.5	mm
Anti-corrosion coating density	1300	Kg/m3
Concrete density	3040	Kg/m3
Content density	729	Kg/m3
Young Modulus	207000	Mpa
Poisson Ratio	0.3	
Corrosion Allowance	-	

4.1.2 Data of Operation Condition

Operation data is used to find out the parameters needed for calculation in the pipeline operation period. The following are Saka Ujung Pangkah's PGN pipeline operational data.

Table 4.2 Pipeline Data
(source: UPD, 2005)

Parameter	Data	Unit
Design Pressure		
Hydrotest Pressure	12400	kPa
Operation Pressure	9000	kPa
Design Temperature	60	C
Operating Temperature		

4.1.3 Environmental Data

Environmental data in the form of seawater density, sea water depth, significant wave height, kinematic viscosity, significant wave period, current velocity, and gravitational acceleration.

Seawater depth and pipe depth are divided according to the zones designated by PGN Saka Ujung Pangkah.

wave data can be seen in the table 4.3 below:

Table 4.3 The Data of wave
(source: UPD, 2005)

Zona	Length of pipe (KP)		Ur	θ_c	Hs	Tz	θ_w
	km						
	From	To	(m/s)	(deg)	(m)	(m/s)	(deg)
Shore	-0.183	3.5	0.32	0	0.54	5.48	0
Zona I	3.5	6.7	0.32	0	0.54	5.48	0
Zona II	6.7	9.3	0.16	0	0.90	5.86	0
Zona III	9.3	11.8	0.16	0	0.90	5.86	0
Zona IV	11.8	15	0.11	0	1.50	6.33	0
Zona V	15	24.2	0.11	0	1.50	6.33	0
Zona VI	24.2	27.6	0.33	0	2.04	6.66	0
Zona VII	27.6	35	0.22	0	3.18	7.15	0
Zona VIII	35	WHP-A	0.17	0	3.18	7.15	0

Current velocity in around of pipeline data can be seen in the table 4.4 below:

Table 4.4 The data of current
(source: UPD, 2005)

Current condition	Location	Current velocity (m/s)
1 years current	Surface	0.70
	Middle	0.65
	Subsea	0.60
100 years currents	Surface	1.10
	Middle	1.05
	Subsea	0.95

The condition of soil in the seabed of pipeline can be seen in the table 4.5 below:

Table 4.5 Data of Soil Conditions
(source: UPD, 2005)

Property	Value	Unit
Mass density of seawater	1017	Kg/m ³
Kinematic viscosity of seawater	8×10^{-7}	M ² /s
Friction factor	0.7	-
Seabed roughness (Z_0) – loose sand	4.17×10^{-5}	M
Seabed roughness (Z_0) – calcarenite/dense/sand/coral	8.33×10^{-4}	M
Seabed roughness (Z_0) – soft clay sand/silt	5.21×10^{-6}	M

4.2 Analysis of Environmental Data

Based on data from PT PGN Saka Energi Pangkah Limited the initial calculation can be determined to determine the wave theory that will be used to determine the waves in each of the determined zones. Determination of wave theory is done by calculating values. Then it can determine the wave propagation value, C, the initial wavelength, L_0 , and the wavelength as a function of depth according to the theory used.

4.2.1 Theory of Wave

To determine the stability of the subsea pipeline the wave theory was determined first to obtain the effective velocity values of particles (U_{eff}) for each zone determined based on Kilometer Point (KP). Determination of wave theory can be determined through the Region of Validity graph by first determining the value.

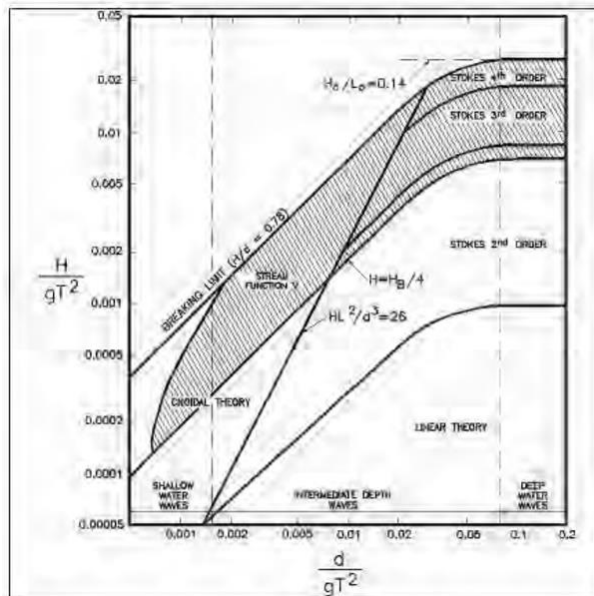

Picture 4.1 Chart of Region of Validity of Wave Theories
(source: Mousselli, 1981)

By looking for the values of H / gt^2 and d / gt^2 then in drawing the line in the graph we can find the wave theory in table 4.6 below :

Table 4.6 Table of Wave Theory Calculation

Zone	Hs	Tp	Depth	g	gt2	H/gt2	d/gt2	Wave Theory
Shore	0,37	4,38	6	9,81	188,199	0,001966	0,031881	Stokes 2
Zona I	0,37	4,38	14	9,81	188,199	0,001966	0,074389	Stokes 2
Zona II	0,78	4,85	13,4	9,81	230,7557	0,0033802	0,05807	Stokes 2
Zona III	0,78	4,85	14	9,81	230,7557	0,0033802	0,06067	Stokes 2
Zona IV	1,34	5,28	15,5	9,81	273,4871	0,0048997	0,056675	Stokes 2
Zona V	1,34	5,28	9,6	9,81	273,4871	0,0048997	0,035102	Stokes 2
Zona VI	2,07	5,64	6,1	9,81	312,0522	0,0066335	0,019548	Stokes 3
Zona VII	2,35	5,74	7,6	9,81	323,216	0,0072707	0,023514	Stokes 3
Zona VIII	2,31	5,73	12,4	9,81	322,0907	0,0071719	0,038498	Stokes 3

4.2.2 Length of Wave and Acceleration of Wave

4.2.2.1 Stokes 2 Wave Theory

From the wave data that has been determined by wave theory used in each zone, it can be calculated the value of the initial wavelength (L_0) by using the following formula.

$$L_0 = \left[\frac{g T^2}{2\pi} \right]$$

$$L_o = \left[\frac{9.8 \cdot 4.85^2}{2 \cdot 3.14} \right]$$

$$L_o = 36,6951 \text{ m}$$

After the value of L_o is obtained, then the wavelength is calculated as a function into (L) using the following formula.

$$L = \left[\frac{g T^2}{2\pi} \right] \tanh \left[\frac{2\pi d}{L} \right]$$

$$L = 36,018 \text{ m}$$

Furthermore, with the obtained value L can be used to calculate the value of wave propagation (C) using the following formula.

$$C = \left[\frac{g T}{2\pi} \right] \tanh \left[\frac{2\pi d}{L} \right]$$

$$C = 6,0741 \text{ m/s}$$

The results of the calculation of the initial wavelength (L_o), Wavelength (L), and wave propagation (C) of stokes 2 wave theory can be seen in the table 4.7 below.

Table 4.7 Table of Wave Theory Calculation

Zona	L_o (Asumtion)	d	d/ L_o	d/L	L	C
Shore	29,927664	6	0,20048	0,2255	26,604	6,0741
Zona I	29,927664	14	0,46779	0,4703	29,766	6,7958
Zona II	36,6951	13,4	0,36517	0,372	36,018	7,4263
Zona III	36,6951	14	0,38152	0,3874	36,135	7,4506
Zona IV	43,490304	15,5	0,3564	0,3638	42,601	8,0683
Zona V	43,490304	9,6	0,22074	0,2427	39,556	7,4916

4.2.2.2 Stokes 3 Wave Theory

To find the value of the wavelength and the acceleration of wave use the same formula in finding initial wavelength (L_o).

$$L_o = \left[\frac{g T^2}{2\pi} \right]$$

$$L_o = \left[\frac{9.8 \cdot 5.73^2}{2 \cdot 3.14} \right]$$

$$L_o = 168.1 \text{ m}$$

Then after the initial length has been obtained, the values of d / L_o , H / d , and d / L can be obtained from the water of finite depth function table (Skjelbreia 1959). After that can be calculated the value of L and C. The results of the calculation of the initial wavelength (L_o), Wavelength (L), and wave propagation (C) of stokes 2 wave theory can be seen in the table 4.7 below.

Table 4. 8 Table of Wave Theory Calculation

Zona	d/Lo	H/d	δ (d/L)	ϵ	L	C
Zona VI	0,037454	0,339344	0,0766244	0,010812	564,17732	100,03144
Zona VII	0,045053	0,309211	0,0857264	0,117264	64,810812	11,291082
Zona VIII	0,073764	0,18629	0,116098	0,10098	122,79622	21,430405

4.2.3 Calculation of Velocity of Water Particles on Pipeline

Based on the wave theory that has been determined, namely the 2nd order stokes wave theory and 3rd order stokes, it can be calculated the speed and acceleration according to the formula for each pipe zone. The calculated speed and wave velocities are those that affect the pipe, which is the depth of the pipe zone waters. Calculation of wave velocity and acceleration can be calculated using the equation below.

4.2.3.1 2nd Order Stokes Wave Theory

To find the velocity of water particles on environmental of pipeline can calculate with formula below.

Horizontal Velocity

$$U = \frac{\pi H}{T} \frac{\cosh h}{\sinh h} \cos \theta + \frac{3}{4} \left(\frac{\pi H}{L} \right) \frac{\pi H}{T} \frac{\cosh^2 ks}{\sinh^2 kd} \cos 2\theta$$

$$U = 1,93498 \text{ m/s}$$

Horizontal Acceleration

$$\frac{u}{t} = \frac{2\pi^2 H}{T} \frac{\cosh ks}{\sinh kd} \cos \theta + \frac{3\pi^2 H}{T^2} \left(\frac{\pi H}{L} \right) \frac{\cosh^2 ks}{\sinh^4 kd} \cos 2\theta$$

$$\frac{u}{t} = 1,93498 \text{ m/s}^2$$

The result of calculation of velocity of seawater particles can be seen in the table 4.9 below.

Table 4.9 Table of Speed of Water Particles Calculation

Zona	u	du/dt	Ue	Ucurr	Uc
Shore	0,51119	4,0806	0,3192	0,25	0,5692
Zona I	1,12286	3,44952	0,62114	0,25	0,87114
Zona II	1,93498	6,2509	1,07711	0,18	1,25711
Zona III	2,06469	6,12983	1,14214	0,18	1,32214
Zona IV	3,76364	8,7812	2,05188	0,1	2,15188
Zona V	2,40037	10,3653	1,40144	0,1	1,50144

4.2.3.2 3rd Order Stokes Wave Theory

To find the velocity of water particles on environmental of pipeline can calculate with formula below.

Horizontal Velocity

$$\mu = C (F1 \text{ Cosh } kS \cos \theta + F2 \text{ Cosh } 2kS \cos \theta + F3 \text{ Cosh } 3kS \cos \theta)$$

$$\mu = 4,3317 \text{ m/s}$$

The result of calculation of velocity of seawater particles can be seen in the table 4.10 below.

Table 4.10 Table of Speed of Water Particles Calculation

Zona	cosh $2\pi S/L$	cosh $4\pi S/L$	cosh $6\pi S/L$
Zona VI	1,01421496	1,057322834	1,130486612
Zona VII	2,345982985	7,482870136	0,446100775
Zona VIII	1,924718725	6,409143315	0,227472724

F1	F2	F3	u	Ucurr	Uc
0,137	0,0573	0,0159	21,754	0,36	22,11
0,13161	0,0415	0,0085	7,0362	0,24	7,276
0,0798	0,0076	0,0004	4,3317	0,17	4,502

4.2.4 Calculation of Soil Friction Calibration Factor

The value of the factor is adjusted to the type of soil seabed and can be searched after finding the value of Carpenter Source (K) and wave velocity current ratio (M). The following table determines the friction calibration factor according to soil classification.

Table 4.11 Table of Friction calibration factor
(source: DNVGL-RP-E305)

Soil types	Friction calibration factor
Sand	0.7
Clay	Based on friction factor graph (DNV RP E305)

After finding the value of Keulegan Carpenter number (K) and wave velocity current ratio (M), the calibration factor value can be obtained with the following graph.

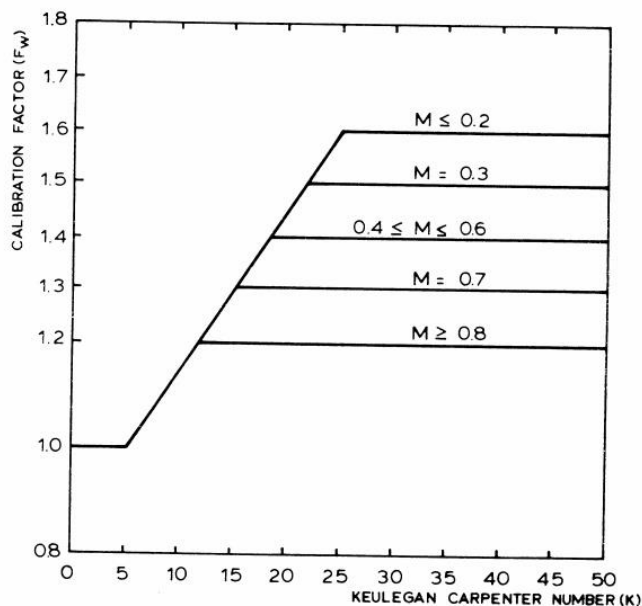

Picture 4.2 Calibration Factor, F_w as Function of 'K and M (source: DNVGL-RP-F-305)

4.2.5 Calculation of Hydrodynamic Forces

After the effective particle velocity value is obtained, the calculation of the hydrodynamic forces acting on the pipe can be calculated.

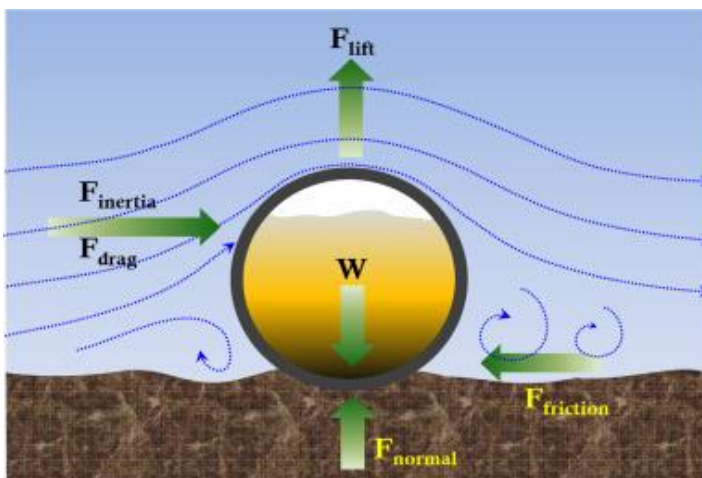

Picture 4.3 Calibration Factor, F_w as Function of 'K and M (source: Clinton, 2015)

Hydrodynamic forces that work include drag force which can be calculated using the following formula

$$F_D = 1/2 \rho C_D (Us \cos\theta + Uc)^2$$

$$F_D = 1/2 \cdot 1025 \cdot 1.2 \cdot 0.536 \cdot 0.4773$$

$$F_D = 157,34788$$

Inertia force which is a force that is influenced by the acceleration of particles transferred by a pipe. Inert force can be calculated using the following formula.

$$F_I = \rho CM \left[\frac{\pi D^2}{4} \right] \left(\frac{dU}{dt} \right)$$

$$F_I = 0,1328$$

Lift force is the vertical force of the pipe which can be calculated using the following formula.

$$FL = 1/2 \rho C_L (Us \cos\theta + Uc)^2$$

$$FL = 118,01091$$

Friction force which is the force acting as a result of the attraction due to friction between the pipe and the surface of the supporting ground.

Table 4.12 Table of Hidrodinamic Forces Calculation

Zone	As	FL	FD	FI
Shore	0,114558	104,78232	139,70976	0,07789
Zona I	0,094829	98,481563	131,30875	0,06448
Zona II	0,195312	118,01091	157,34788	0,1328
Zona III	0,19028	116,60778	155,47704	0,12937
Zona IV	0,275969	140,53953	187,38604	0,18764
Zona V	0,583856	261,44826	348,59768	0,39697
Zona VI	0,699382	330,79771	441,06361	0,47552
Zona VII	0,657483	311,88265	415,84353	0,44703
Zona VIII	0,732252	303,60129	404,80172	0,49787

The value of the hydrodynamics forces is used to calculate the submerged weight of the required pipe (Ws_{req}). the value of the factor is adjusted to the type of soil seabed.

4.2.6 Modelling and Validation of Hydrodynamics forces

Modelling using Ansys software to know the value of drag force due to the pipeline. The variable that inputed is the velocity of particle, 0,486 can be seen on the figure below.

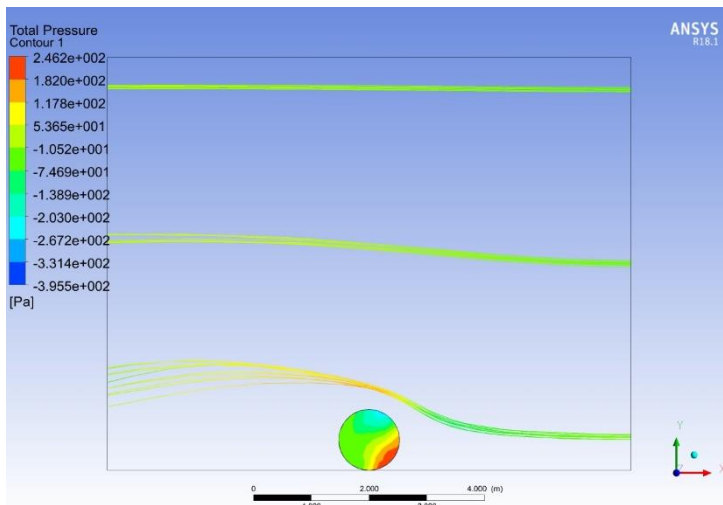

Picture 4.4 Simulation of Hydrodynamics Force on Pipeline

Based on the results of simulations carried out using Ansys software, the horizontal force of the pipe is 408.1799 N. compared to the results of manual calculations with the results of the software.

Modelling : Manual calculation 408.1799 : 404.80172

Margin error is 0.0083, so the results of simulation using software can be said to be valid based on comparisons with calculations that comply with DNVGL-RP-F109 standards.

4.2.7 Calculation Of Minimum Submerged Weight Pipe

From the values of the hydrodynamic forces that have been obtained and calibrated from the coefficient of friction, a calculation can be made to find the minimum submerged weight of the pipe.

To get the value of the submerged pipe we use the formula in accordance with DNV RP F-109

$$W_{s_req} = \left[\frac{(F_D + F_I) + \mu \cdot F_L}{\mu} \right] \cdot F_W$$

$$W_{s_req} = \left[\frac{(157,34788 + 0,1328) + 0,5 \cdot 118,01091}{0,5} \right] \cdot F_W$$

$$W_{s_req} = 432,972 \text{ N}$$

The result of calculation of submerged weight requirement of subsea pipeline in the Ujung Pangkah sea.

Table 4.13 Table of Submerged Weight Requirements Calculation

Zone	u	Ws req
Shore	0,5	384,358
Zona I	0,5	361,228
Zona II	0,5	432,972
Zona III	0,5	427,821
Zona IV	0,5	515,687
Zona V	0,5	959,438
Zona VI	0,5	1274,57
Zona VII	0,5	1190,24
Zona VIII	0,5	1147,63

4.3 Pipe property calculation

Before carrying out the analysis related to the stability of the PGN subsea pipeline, a pipe property calculation was carried out to determine the existing conditions of the pipe. Many factors influence the reliability of subsea gas pipes, pipe weight, pressure on pipes, temperature, load contents of subsea pipes, anomaly or damage to pipes, etc. These factors can affect the reliability of the pipe as a gas distributor from upstream to the receiving station. Therefore several factors that influence the reliability of the pipe can be obtained through the calculation of pipe properties as follows:

Outside diameter of pipe

$$D = D_o + 2t_{cor} + 2t_c$$

$$D = 536 \text{ mm}$$

$$D = 0.536 \text{ m}$$

Inner diameter of pipe

$$D_i = D_o - 2t_{st}$$

$$D_i = 427.4 \text{ mm}$$

$$D_i = 0.4274 \text{ m}$$

Weight steel (W_{st})

$$W_{st} = \frac{\pi}{4} \rho_{st} (D_o^2 - D_t^2)$$

$$W_{st} = 161.31 \text{ N}$$

Weight corrotion (W_{corr})

$$W_{corr} = \frac{\pi}{4} \rho_{corr} [(D_o + 2 t_{corr})^2 - D_t^2] g$$

$$W_{corr} = 363.93 \text{ N}$$

Weight concrete (W_c)

$$W_c = \frac{\pi}{4} \rho_c [(D_o + 2 t_{corr} + 2 t_c)^2 - (D_o + 2 t_{corr})^2] g$$

$$W_c = 1598,2874 \text{ N}$$

Weight of contain (W_{cont})

$$W_{cont} = D t^2 \rho_{cont} g$$

$$W_{cont} = 1306,3681 \text{ N}$$

Bouancy (B)

$$B = \frac{\pi}{4} \rho_w (D_o + 2 t_{corr} + 2 t_c)^2 g$$

$$B = 2267,734 \text{ N}$$

Submerged Weight of pipe

$$W_s = W_{st} + W_{corr} + W_c + W_{cont} - B$$

$$W_s = 1162,1745 \text{ N}$$

4.4 Calculation of Lateral And Vertical Stability Analysis

To analyze the stability of the subsea pipeline, one of the analytical methods that can be used, in DNV Rp. 109 is the lateral static stability as a whole. The general equation of this method is

$$\gamma_{sc} = \frac{(W_s - FL) \cdot \mu}{FD \cdot FI} \geq 1.0$$

$$\gamma_{sc} = \frac{(1162.1745 - 118.01091) \cdot 0.5}{157.34788 \cdot 0.1328} \geq 1.1$$

$$\gamma_{sc} = 3,31521 \geq 1.1$$

The result of calculation of of lateral stability can seen in table 4.14 below.

Table 4.14 Table of Lateral Stability Calculation

Zone	ysc	comment
Shore	3,78214	OK
Zona I	4,04836	OK
Zona II	3,31521	OK
Zona III	3,35965	OK
Zona IV	2,72329	OK
Zona V	1,29046	OK
Zona VI	0,94145	Need_More_Thickness
Zona VII	1,02127	Need_More_Thickness
Zona VIII	1,05918	Need_More_Thickness

There are pipelines in zona VI, zona VII, zona VIII of gas PGN pipelines that not stable, because the weight of pipeline in operation time is not require the safety factor of lateral stability.

While the analysis of vertical stability using the following equation.

$$\gamma_w = \frac{Ws + b}{b} = \frac{Sg}{\gamma_w} \geq 1.0$$

$$\gamma_w = \frac{1162,1745 + 2267.734}{2267.734} \geq 1.0$$

The result of calculation of of vertical stability can seen in table 4.14 below.

Table 4.15 Table of Vertical Stability Calculation

Zone	yw	comment
Shore	1,512483	OK
Zona I	1,512483	OK
Zona II	1,512483	OK
Zona III	1,512483	OK
Zona IV	1,512483	OK
Zona V	1,512483	OK
Zona VI	1,512483	OK
Zona VII	1,512483	OK
Zona VIII	1,512483	OK

4.5 Analisis of Stability of Pipe on Different Types of Soil

The results of the analysis with variations in the thickness of concrete coating and its effect on vertical stability and lateral stability are shown in Table 4.16 below.

Table 4.16 Table of Stability of Pipe on Different Types of Soil Calculation

Thickness	Soft Clay		Silty Sand		Clay	
	VS	LS	VS	LS	VS	LS
30	1,46811	2,027	1,46811	2,6063	1,46811	2,8959
34	1,51248	2,321	1,51248	2,9837	1,51248	3,3152
40	1,57544	2,769	1,57544	3,5605	1,57544	3,9561
50	1,67163	3,539	1,67163	4,5501	1,67163	5,0557
60	1,75817	4,336	1,75817	5,5753	1,75817	6,1948

The result of with variations in the thickness of concrete coating and its effect on vertical stability can analyze with graph 4.5 below.

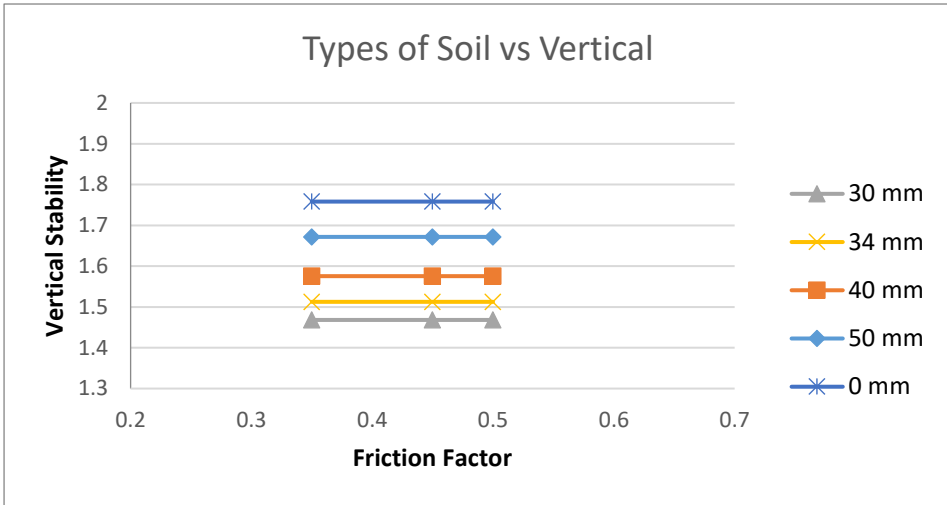

Picture 4.5 Correlation of Types of Soil and Vertical Stability

In the graph it can be seen that the pipe is stable, because it meets vertical and lateral direction stability which is greater than or equal to 1.1. The graph pattern shows the increasing thickness of the concrete layer the better the stability produced. For vertical stability calculated on the condition of the seabed, soft clay, silty sand and clay produce the same increase in stability as the thickness of the concrete layer increases.

The result of with variations in the thickness of concrete coating and its effect on vertical stability can analyze with graph 4.6 below.

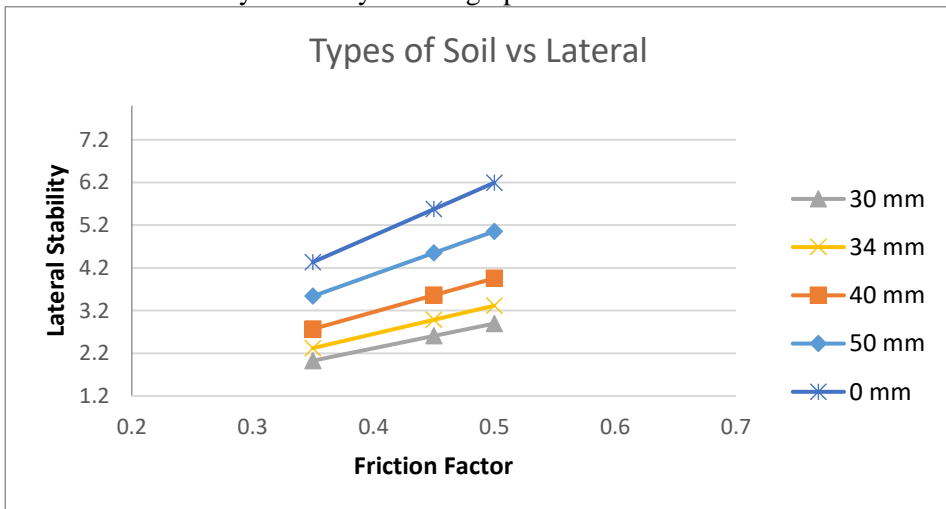

Picture 4.6 Correlation of Types Of Soil and Lateral Stability

In the graph it can be seen that the pipe is stable, because it meets vertical and lateral direction stability which is greater than or equal to 1.1. The graph pattern

shows the increasing thickness of the concrete layer the better the stability produced. For both vertical and lateral stability calculated on the condition of the seabed, soft clay, silty sand and clay produce the same increase in stability as the thickness of the concrete layer increases. For lateral stability in soft clay seabed conditions, lateral stability is smaller than the condition of the seabed silty sand and lateral stability in the condition of the seabed silty sand having lateral stability that is smaller than clay seabed conditions due to differences in coefficient of friction

4.6 Analisis of Stability of Pipe in Different Thickness of Concrete

The results of the analysis with variations in the thickness of concrete coating and its effect on vertical stability and lateral stability are shown in Table 4.17 below.

Table 4.17 Table of Stability of Pipe on Different Thickness of Concrete Calculation

Thickness	Soft Clay		Silty Sand		Clay	
	VS	LS	VS	LS	VS	LS
30	1,4681	2,027	1,4681	2,606	1,4681	2,8959
34	1,5125	2,321	1,5125	2,984	1,5125	3,3152
40	1,5754	2,769	1,5754	3,56	1,5754	3,9561
50	1,6716	3,539	1,6716	4,55	1,6716	5,0557
60	1,7582	4,336	1,7582	5,575	1,7582	6,1948

The result of with variations of type of soil and its effect on vertical stability can analyze with graph 4.7 below .

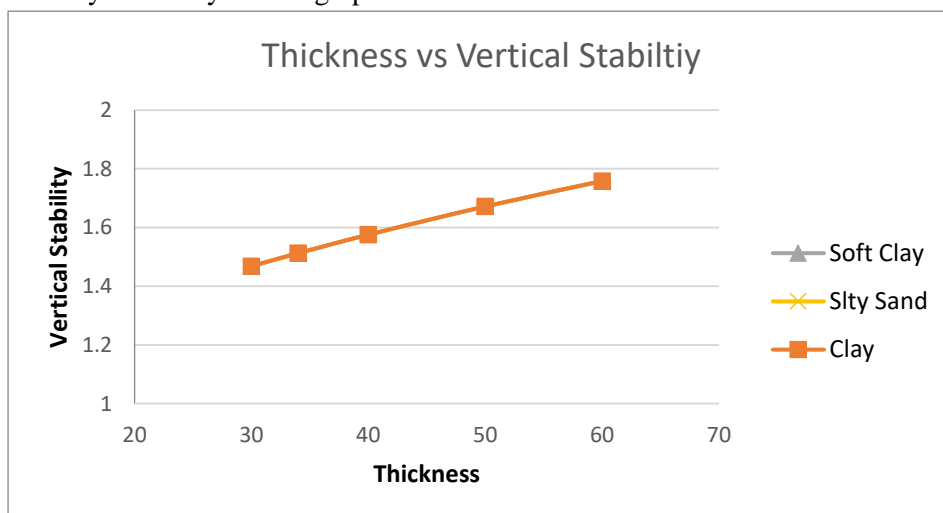

Picture 4.7 Correlation of Thickness of Concrete and Vertical Stability

The graph 4.7 shows a graph of vertical stability due to the effect of variations in concrete coating thickness. It means that the thicker the concrete layer, the better the effect on vertical stability. So the weight value of the pipe will increase along with the thickness of the concrete so that the value of pipe stability also increases. Vertical stability calculated on the seabed clay conditions were greater than the seabed silty sand conditions and vertical stability calculated on the seabed silty sand conditions greater than the conditions of the soft clay seabed.

The result of with variations of type of soil and its effect on lateral stability can analyze with graph 4.8 below

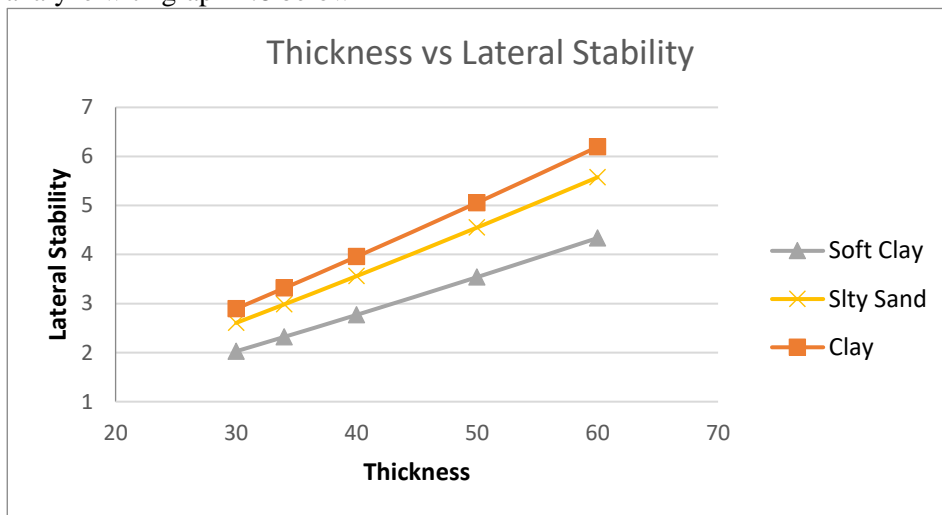

Picture 4.8 Correlation of Thickness of Concrete and Vertical Stability

The graph 4.8 shows a graph of vertical stability and lateral stability due to the effect of variations in concrete coating thickness. It means that the thicker the concrete layer, the better the effect on lateral stability. So the weight value of the pipe will increase along with the thickness of the concrete so that the value of pipe stability also increases. Lateral stability calculated on the seabed clay conditions were greater than the seabed silty sand conditions and lateral stability calculated on the seabed silty sand conditions greater than the conditions of the soft clay seabed.

4.7 Analysis of pipeline movements when due to hydrodynamic forces

Because of the pipeline in zona VI, zona VII, zona VIII of gas PGN pipelines that not stable. So, from not stable pipeline found the how far deformation of pipeline from initial position. The results of the analysis obtained from the modelling pipeline to find out how far the pipeline shift when exposed to the hydrodynamic force can be seen in the range below.

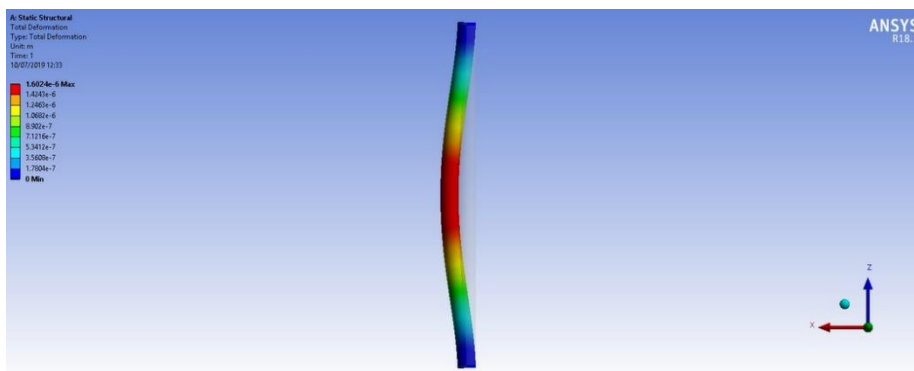

Picture 4.8 Deformation of Pipeline Based on Simulation

Based on the picture, it can be seen that the pipeline when the hydrodynamic force is dragged with a force of 404.8 N shifts a maximum of 0.00265 mm from its original position. Therefore we need the stability that meets the safety factor requirements so that the pipeline does not shift due to the hydrodynamic force.

“This page is intentionally left blank”

CHAPTER V CONCLUSION

5.1 Conclusion

1. The external forces acting on the pipe and their effect on pipe stability. Drag force is the force resulting from the force produced by the undersea currents that affect the pipe. The lifting force is a force derived from seawater that fights the normal force of the pipe, and the inertia force is the force derived from the moment of pipe inertia. The thicker the concrete will lead to greater lift force, inertia force and drag force due to the concrete thickness affecting the pipe diameter so that the cross-sectional area affected by the force is also wider so that the hydrodynamic forces become large in line with increasing concrete thickness

Zone	As	FL	FD	FI
Shore	0,114558	104,78232	139,70976	0,07789
Zona I	0,094829	98,481563	131,30875	0,06448
Zona II	0,195312	118,01091	157,34788	0,1328
Zona III	0,19028	116,60778	155,47704	0,12937
Zona IV	0,275969	140,53953	187,38604	0,18764
Zona V	0,583856	261,44826	348,59768	0,39697
Zona VI	0,699382	330,79771	441,06361	0,47552
Zona VII	0,657483	311,88265	415,84353	0,44703
Zona VIII	0,732252	303,60129	404,80172	0,49787

2. From the values of the hydrodynamic forces that have been obtained and calibrated from the coefficient of friction, a calculation can be made to find the minimum submerged weight of the pipe.

The result of calculation of submerged weight requirement of subsea pipeline in the Ujung Pangkah sea.

Zone	u	Ws req
Shore	0,5	384,358
Zona I	0,5	361,228
Zona II	0,5	432,972
Zona III	0,5	427,821
Zona IV	0,5	515,687
Zona V	0,5	959,438
Zona VI	0,5	1274,57
Zona VII	0,5	1190,24
Zona VIII	0,5	1147,63

The value of submerged weight of pipeline is 1162,1745 N. Based on table calculation of submerged weight requirement, So the result of submerged weight calculation and submerged weight requirement calculation there are submerged weight pipelines not qualify to submerged weight requirement in zone VI, zone VII, and zone VIII.

3. The seabed condition also affects the stability of the pipe due to the friction between the pipe and the seabed surface which makes the force in the opposite direction from the direction of the drag force which is one of the hydrodynamic forces that affects the stability of the subsea pipeline. The greater the friction factor of the type of surface of the seabed, the greater the friction force and the better the stability of the subsea pipeline. As found in the graph below.

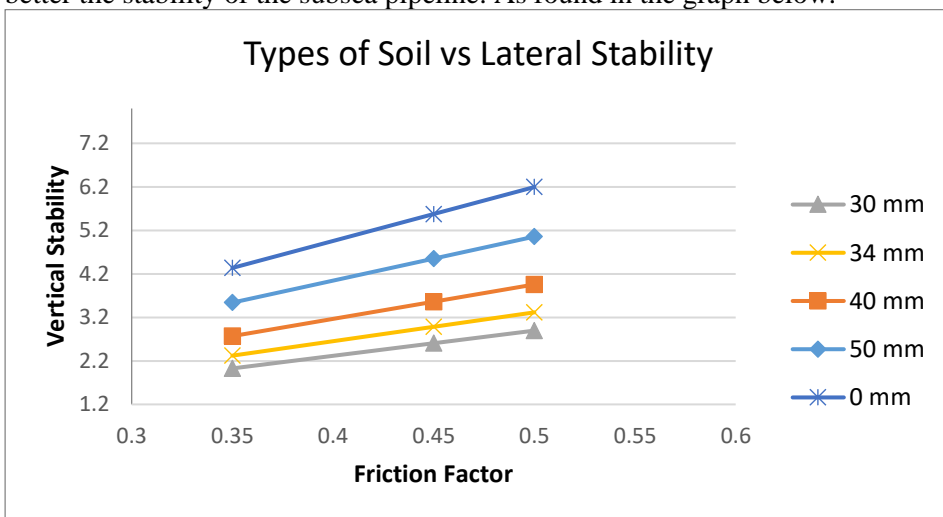

The thickness variations of concrete coating used in this final project are 30 mm, 40 mm, 50 mm, and 60. Every variation that counts, not all of them meet the lateral safety factor, which is greater than or equal to 1.1. But all of them meet the vertical safety factor. The value of the safety factor is best shown when the thickness of the concrete layer is 60mm. So the thickness of the concrete layer of 60 mm can be taken as a reference for the stability of safer underwater pipes. Results calculated on soft clay seabed conditions (TCC 60 mm, VS = 1,7582, LS = 4,336), silty sand (TCC 60 mm, VS = 1,7582, LS = 5,575) and on the clay seabed condition (TCC 60 mm, VS = 1,7582, LS = 6,1948).

5.2 Suggestion

1. The stability analysis method used in this final project is Absolute Lateral Static Stability Method (DNV RP F109) and Simplified Stability Analysis for DNV Rp.

- E305. In addition, other methods of analysis can be used, namely Dynamic Lateral Stability Analysis and Generalized Lateral Stability Method on DNV RP F109.
2. For further research, it is necessary to analyze the cost of both the stability of the subsea pipeline calculated by DNV RP F109 and DNV RP E305, then compared.

“This page is intentionally left blank”

REFERENCES

- Riski, Rahmat. 2011. Analisa Stabilitas Pipa Bawah Laut Dengan Metode Dnv Rp F109 : Studi Kasus Proyek Instalasi Pipeline Dari Platform Eza Menuju Platform Ura Sepanjang 7.706 Km Di Laut Jawa. Surabaya
- Prabowo, Himawan Khalid. 2014. Desain Bisnis dan Analisa Stabilitas Pipa Gas Bawah Laut. Surabaya.
- Sibuea, Clinton. 2015. Analisis On-Bottom Stability dan Local Buckling: Studi Kasus Pipa Bawah Laut dari Platform Ula Menuju Platform Uw. Surabaya
- Tian, Yinghui., Cassidy, Mark J. , Chang, Chee Khang. 2014. Assessment Of Offshore Pipelines Using Dynamic Lateral Stability Analysis. Crawley. Elsevier.
- Tian, Yinghui., Yuessef, Bassem., Cassidy, Mark J. 2015. Assessment Of Pipeline Stability In The Gulf Of Mexico During Hurricanes Using Dynamic Analysis. Crawley. Elsevier.
- Yu, Su Young., Choi, Han Suk., etc. An Optimum Design Of On-Bottom Stability Of Offshore Pipelines On Soft Clay. Ulsan. JNAOE.
- Yu, Su Young., Choi, Han Suk., etc. Nonlinear Soil Parameter Effects On Dynamic Embedment Of Offshore Pipeline On Soft Clay. Ulsan. JNAOE.
- Dong, J., Chen, X.D., ets. 2015. Local Buckling Analysis of Free Span for Submarine Pipeline. Changjiang. Elsevier
- Bai, Y., Bai, Q. 2005. Subsea Pipelines and Risers. Elsevier Science, USA
- Det norske Veritas. 2010. DNV RP F109, On-bottom stability design of submarine pipelines. Norway.
- Det norske Veritas. 2013. DNV OS F101, Submarine pipeline systems. Norway
- Indiyono, Paul. 2004. Hidrodinamika Bangunan Lepas Pantai. Surabaya. SIC
- Mousselli. 1981. Offshore Pipeline Design, Analysis, and Methods. Tulsa. Pennwell Corp.
- Triadmodjo, Bambang. 1999. Teknik Pantai. Yogyakarta.
- UPD-RG-F1-PL-BD-3800. 2005. Pipeline Basic of Design. Ujung Pangkah.
- UPD-RG-F1-PL-RP-3800. 2005. Pipeline Protection Risk Assessment. Ujung Pangkah.

“This page is intentionally left blank”

ATTACHMENTS

“This page is intentionally left blank”

Calculation of Property of pipeline

Parameter	Data	Unit
Outer Diameter	457	mm
Material	Steel	
Wall Thickness	14,8	mm
SMYS	448	Mpa
Stell Density	7850	Kg/m3
Anti-corrosion coating thickness	5,5	mm
Anti-corrosion coating density	1300	Kg/m3
Concrete density	3040	Kg/m3
tcc	34	mm
Content Density	729	Kg/m3
Young Modulus	207000	Mpa
Poisson ratio	0,3	

Outside diameter of pipe

$$D = D_o + 2t_{cor} + 2t_c$$

$$D = 536 \text{ mm}$$

$$D = 0.536 \text{ m}$$

Inner diameter of pipe

$$D_i = D_o - 2t_{st}$$

$$D_i = 427.4 \text{ mm}$$

$$D_i = 0.4274 \text{ m}$$

Weight steel (W_{st})

$$W_{st} = \frac{\pi}{4} \rho_{st} (D_o^2 - D_i^2)$$

$$W_{st} = 161.31 \text{ N}$$

Weight corrotion (W_{corr})

$$W_{corr} = \frac{\pi}{4} \rho_{corr} [(D_o + 2 t_{corr})^2 - D_i^2] g$$

$$W_{corr} = 363.93 \text{ N}$$

Weight concrete (W_c)

$$W_c = \frac{\pi}{4} \rho_c [(D_o + 2 t_{corr} + 2t_c)^2 - (D_o + 2 t_{corr})^2] g$$

$$W_c = 1598,2874 \text{ N}$$

Weight of contain (W_{cont})

$$W_{cont} = Dt^2 \rho_{cont} g$$

$$W_{cont} = 1306,3681 \text{ N}$$

Bouancy (B)

$$B = \frac{\pi}{4} \rho_w (D_o + 2 t_{corr} + 2t_c)^2 g$$

$$B = 2267,734 \text{ N}$$

Submerged Wieight of pipe

$$W_s = W_{st} + W_{corr} + W_c + W_{cont} - B$$

$$W_s = 1162,1745 \text{ N}$$

$$T_{cc} = 30 \text{ mm}$$

Outside diameter of pipe

$$D = D_o + 2t_{cor} + 2t_c$$

$$D = 528 \text{ mm}$$

$$D = 0.528 \text{ m}$$

Inner diameter of pipe

$$D_i = D_o - 2t_{st}$$

$$D_i = 427.4 \text{ mm}$$

$$D_i = 0.4274 \text{ m}$$

Weight steel (W_{st})

$$W_{st} = \frac{\pi}{4} \rho_{st} (D_o^2 - D_t^2)$$

$$W_{st} = 161.31 \text{ N}$$

Weight corrotion (W_{corr})

$$W_{corr} = \frac{\pi}{4} \rho_{corr} [(D_o + 2 t_{corr})^2 - D_t^2] g$$

$$W_{corr} = 363.93 \text{ N}$$

Weight concrete (W_c)

$$W_c = \frac{\pi}{4} \rho_c [(D_o + 2 t_{corr} + 2t_c)^2 - (D_o + 2 t_{corr})^2] g$$

$$W_c = 1399,0165 \text{ N}$$

Weight of contain (W_{cont})

$$W_{cont} = Dt^2 \rho_{cont} g$$

$$W_{cont} = 1306,3681 \text{ N}$$

Bouancy (B)

$$B = \frac{\pi}{4} \rho_w (D_o + 2 t_{\text{corr}} + 2 t_c)^2 g$$

$$B = 2200,5456 \text{ N}$$

Submerged Weight of pipe

$$W_s = W_{\text{st}} + W_{\text{corr}} + W_c + W_{\text{cont}} - B$$

$$W_s = 1030,092 \text{ N}$$

$$T_{\text{cc}} = 40 \text{ mm}$$

Outside diameter of pipe

$$D = D_o + 2 t_{\text{corr}} + 2 t_c$$

$$D = 548 \text{ mm}$$

$$D = 0.548 \text{ m}$$

Inner diameter of pipe

$$D_i = D_o - 2 t_{\text{st}}$$

$$D_i = 427.4 \text{ mm}$$

$$D_i = 0.4274 \text{ m}$$

Weight steel (W_{st})

$$W_{\text{st}} = \frac{\pi}{4} \rho_{\text{st}} (D_o^2 - D_i^2) g$$

$$W_{\text{st}} = 161.31 \text{ N}$$

Weight corrosion (W_{corr})

$$W_{\text{corr}} = \frac{\pi}{4} \rho_{\text{corr}} [(D_o + 2 t_{\text{corr}})^2 - D_i^2] g$$

$$W_{\text{corr}} = 363.93 \text{ N}$$

Weight concrete (W_c)

$$W_c = \frac{\pi}{4} \rho_c [(D_o + 2 t_{\text{corr}} + 2 t_c)^2 - (D_o + 2 t_{\text{corr}})^2] g$$

$$W_c = 1598,2874 \text{ N}$$

Weight of contain (W_{cont})

$$W_{\text{cont}} = D t^2 \rho_{\text{cont}} g$$

$$W_{\text{cont}} = 1902,8123 \text{ N}$$

Bouancy (B)

$$B = \frac{\pi}{4} \rho_w (D_o + 2 t_{\text{corr}} + 2 t_c)^2 g$$

$$B = 2370,411 \text{ N}$$

Submerged Weight of pipe

$$W_s = W_{st} + W_{corr} + W_c + W_{cont} - B$$

$$W_s = 1364,0224 \text{ N}$$

$$T_{cc} = 50 \text{ mm}$$

Outside diameter of pipe

$$D = D_o + 2t_{cor} + 2t_c$$

$$D = 568 \text{ mm}$$

$$D = 0.568 \text{ m}$$

Inner diameter of pipe

$$D_i = D_o - 2t_{st}$$

$$D_i = 427.4 \text{ mm}$$

$$D_i = 0.4274 \text{ m}$$

Weight steel (W_{st})

$$W_{st} = \frac{\pi}{4} \rho_{st} (D_o^2 - D_i^2)$$

$$W_{st} = 161.31 \text{ N}$$

Weight corrosion (W_{corr})

$$W_{corr} = \frac{\pi}{4} \rho_{corr} [(D_o + 2 t_{corr})^2 - D_i^2] g$$

$$W_{corr} = 363.93 \text{ N}$$

Weight concrete (W_c)

$$W_c = \frac{\pi}{4} \rho_c [(D_o + 2 t_{corr} + 2t_c)^2 - (D_o + 2 t_{corr})^2] g$$

$$W_c = 2425,3365 \text{ N}$$

Weight of contain (W_{cont})

$$W_{cont} = D_i^2 \rho_{cont} g$$

$$W_{cont} = 1306,3681 \text{ N}$$

Bouancy (B)

$$B = \frac{\pi}{4} \rho_w (D_o + 2 t_{corr} + 2t_c)^2 g$$

$$B = 2546,591 \text{ N}$$

Submerged Weight of pipe

$$W_s = W_{st} + W_{corr} + W_c + W_{cont} - B$$

$$W_s = 1710,3666 \text{ N}$$

$$T_{cc} = 60 \text{ mm}$$

Outside diameter of pipe

$$D = D_o + 2t_{cor} + 2t_c$$

$$D = 588 \text{ mm}$$

$$D = 0.588 \text{ m}$$

Inner diameter of pipe

$$D_i = D_o - 2t_{st}$$

$$D_i = 427.4 \text{ mm}$$

$$D_i = 0.4274 \text{ m}$$

Weight steel (W_{st})

$$W_{st} = \frac{\pi}{4} \rho_{st} (D_o^2 - D_i^2)$$

$$W_{st} = 161.31 \text{ N}$$

Weight corrosion (W_{corr})

$$W_{corr} = \frac{\pi}{4} \rho_{corr} [(D_o + 2 t_{corr})^2 - D_i^2] g$$

$$W_{corr} = 363.93 \text{ N}$$

Weight concrete (W_c)

$$W_c = \frac{\pi}{4} \rho_c [(D_o + 2 t_{corr} + 2t_c)^2 - (D_o + 2 t_{corr})^2] g$$

$$W_c = 2966,5892 \text{ N}$$

Weight of contain (W_{cont})

$$W_{cont} = D_i^2 \rho_{cont} g$$

$$W_{cont} = 1306,3681 \text{ N}$$

Bouancy (B)

$$B = \frac{\pi}{4} \rho_w (D_o + 2 t_{corr} + 2t_c)^2 g$$

$$B = 2729,0857 \text{ N}$$

Submerged Wieht of pipe

$$W_s = W_{st} + W_{corr} + W_c + W_{cont} - B$$

$$W_s = 2069,1245 \text{ N}$$

Input parameter

Phase : Operation
 Wave/Current Data : 100 year period
 Design life : 30 years

Pipe Property Data

Outer Diameter Do = 475 mm
 Wall Thickness t_{st} = 14.8 mm
 Steel Density ρ_{st} = 7850 kg/m³
 Anti-corrosion coating thickness t_{corr} = 5.5 mm
 Anti-corrosion density ρ_{corr} = 1300 kg/m³
 Concrete density ρ_{cc} = 3040 kg/m³
 Content density ρ_{cont} = 729 kg/m³

Young Modulus

Poisson Ratio

Environmental Data

Seawater density ρ_{sw} = 1025 kg/m³
 Kinematic viscosity ν = 8.10⁻⁷
 Depth d = 13.4 m
 Height of significant wave H_s = 0.9 m
 Period of significant wave T_z = 5.86 m
 Peak period T_p = 4.85 m
 Current velocity U_{curr} = 0.17 m/s

Soil parameter

Soil type Clay soil
 Soil friction factor μ = 0.5
 Seabed roughness Z_o = 5x10⁻⁶ m

Calculation of wave theory

$$Y = \frac{H}{g T^2}$$

$$= \frac{0,78}{9,81 \cdot 4,85^2}$$

$$= 0,338$$

$$X = \frac{d}{g T^2}$$

$$= \frac{13,4}{9,81 \cdot 4,85^2}$$

$$= 0,58$$

Wave theory : 2nd order stokes wave theory

Zone	Hs	Tp	Depth	g	gt ²	H/gt ²	d/gt ²	Wave Theory
Shore	0,37	4,38	6	9,81	188,199	0,001966	0,031881	Stokes 2
Zona I	0,37	4,38	14	9,81	188,199	0,001966	0,074389	Stokes 2
Zona II	0,78	4,85	13,4	9,81	230,7557	0,0033802	0,05807	Stokes 2
Zona III	0,78	4,85	14	9,81	230,7557	0,0033802	0,06067	Stokes 2
Zona IV	1,34	5,28	15,5	9,81	273,4871	0,0048997	0,056675	Stokes 2
Zona V	1,34	5,28	9,6	9,81	273,4871	0,0048997	0,035102	Stokes 2
Zona VI	2,07	5,64	6,1	9,81	312,0522	0,0066335	0,019548	Stokes 3
Zona VII	2,35	5,74	7,6	9,81	323,216	0,0072707	0,023514	Stokes 3
Zona VIII	2,31	5,73	12,4	9,81	322,0907	0,0071719	0,038498	Stokes 3

Calculation of wavelength

$$L_0 = \frac{g T^2}{2\pi} \tan \frac{2\pi d}{L_0}$$

$$L_0 = 36,6951$$

From graph 3.7 wave length and height variations with depth (Mouselle, 1981)

$$d/L_0 = 0,3652$$

$$d/L = 0,372$$

$$L = 36,018$$

Zona	Lo (Asumtion)	d	d/Lo	d/L	L
Shore	29,927664	6	0,2005	0,2255	26,604
Zona I	29,927664	14	0,4678	0,4703	29,766
Zona II	36,6951	13,4	0,3652	0,372	36,018
Zona III	36,6951	14	0,3815	0,3874	36,135
Zona IV	43,490304	15,5	0,3564	0,3638	42,601
Zona V	43,490304	9,6	0,2207	0,2427	39,556

Calculation of Speed of Water Particles on Pipes

Horizontal Velocity

$$U = \frac{\pi H}{T} \frac{\cosh h}{\sinh h} \cos \theta + \frac{3}{4} \left(\frac{\pi H}{L} \right) \frac{\pi H}{T} \frac{\cos h^2 ks}{\sin h^2 kd} \cos 2\theta$$

Horizontal Acceleration

$$\frac{u}{t} = \frac{2\pi^2 H}{T} \frac{\cos h ks}{\sin h kd} \cos \theta + \frac{3\pi^2 H}{T^2} \left(\frac{\pi H}{L} \right) \frac{\cos h^2 ks}{\sin h^4 kd} \cos 2\theta$$

Zona	$2\pi d/L$	$\cosh k(d+y)$	$4\pi d/L$	$\cosh 2k(d+y)$	$2\pi d/L$	$\sinh kd$	u
Shore	1,6524	2,705467912	3,3047	13,64289643	1,4163	1,93973	0,51119
Zona I	3,1647	11,86184847	6,3294	280,4172531	2,9537	9,5626	1,12286
Zona II	2,5108	6,197683338	5,0216	75,82304416	2,3364	5,09316	1,93498
Zona III	2,6069	6,815285306	5,2137	91,89080353	2,4331	5,65503	2,06469
Zona IV	2,4324	5,736751489	4,8647	64,81887663	2,2849	4,8615	3,76364
Zona V	1,6829	2,783549018	3,3658	14,49292195	1,5241	2,18671	2,40037

Perhitungan kecepatan arus

$$U_D = U_r \left[\frac{\left(1 + \frac{z_o}{D}\right) \cdot \left(\ln \left(\frac{D}{z_o} + 1\right) - 1\right)}{\ln \left(\frac{z_r}{z_o} + 1\right)} \right] \cdot \sin(\theta_{curr})$$

$$U_D = 0.531$$

$$M = \frac{U_D}{U_s}$$

$$M = 3.321$$

$$K = \frac{U_s \cdot T u}{D}$$

$$K = 1.446$$

$$F_w = 1$$

Calculation Hydrodynamic forces

$$F_D = 1/2 \rho C_D D U e^2$$

$$F_D = 154,6611$$

$$F_I = \rho C_M \left[\frac{\pi D^2}{4} \right] \left(\frac{dU}{dt} \right)$$

$$F_I = 0,128861$$

$$F_L = 1/2 \rho C_L D U e^2$$

$$F_L = 115,99579$$

Zone	As	FL	FD	FI
Shore	0,114558	102,96341	137,2845	0,075582
Zona I	0,094829	96,76448	129,0193	0,062566
Zona II	0,195312	115,99579	154,6611	0,128861
Zona III	0,19028	114,61512	152,8202	0,125541
Zona IV	0,275969	138,17697	184,236	0,182076
Zona V	0,583856	257,18462	342,9128	0,385211
Zona VI	1,538639	930,7979	1241,064	1,01515
Zona VII	1,346274	780,16625	1040,222	0,888233
Zona VIII	0,732252	298,6967	398,2623	0,483118

Calculation of Lateral And Vertical Stability Analysis

In DNV RP-109 is the lateral static stability as a whole. The general equation of this method is

$$\gamma_{sc} = \frac{(W_s - F_L) \cdot \mu}{F_D + F_R} \geq 1.0$$

$$\gamma_{sc} = 3,596381 \geq 1.0$$

Zone	ysc	comment
Shore	4,100169	OK
Zona I	4,387132	OK
Zona II	3,596381	OK
Zona III	3,64426	OK
Zona IV	2,958458	OK
Zona V	1,415939	OK
Zona VI	1,040352	OK
Zona VII	1,126205	OK
Zona VIII	1,166993	OK

While the analysis of vertical stability using the following equation

$$\gamma_w = \frac{Ws + b}{b} \geq 1.0$$

$$\gamma_w = 1,558663 \geq 1.0$$

Zone	yw	comment
Shore	1,558663	OK
Zona I	1,558663	OK
Zona II	1,558663	OK
Zona III	1,558663	OK
Zona IV	1,558663	OK
Zona V	1,558663	OK
Zona VI	1,558663	OK
Zona VII	1,558663	OK
Zona VIII	1,558663	OK

Input parameter

Phase : Operation
 Wave/Current Data : 100 year period
 Design life : 30 years

Pipe Property Data

Outer Diameter $D_o = 475$ mm
 Wall Thickness $t_{st} = 14.8$ mm
 Steel Density $\rho_{st} = 7850$ kg/m³
 Anti-corrosion coating thickness $t_{corr} = 5.5$ mm
 Anti-corrosion density $\rho_{corr} = 1300$ kg/m³
 Concrete density $\rho_{cc} = 3040$ kg/m³
 Content density $\rho_{cont} = 729$ kg/m³

Young Modulus

Poisson Ratio

Environmental Data

Seawater density $\rho_{sw} = 1025$ kg/m³
 Kinematic viscosity $\nu = 8.10^{-7}$
 Depth $d = 13.4$ m
 Height of significant wave $H_s = 0.9$ m
 Period of significant wave $T_z = 5.86$ m
 Peak period $T_p = 4.85$ m
 Current velocity $U_{curr} = 0.17$ m/s

Soil parameter

Soil type Clay soil
 Soil friction factor $\mu = 0.5$
 Seabed roughness $Z_o = 5 \times 10^{-6}$ m

Calculation of wave theory

$$\begin{aligned}
 Y &= \frac{H}{g T^2} \\
 &= \frac{0.78}{9.81 \cdot 4.85^2} \\
 &= 0.338
 \end{aligned}$$

$$\begin{aligned}
 X &= \frac{d}{g T^2} \\
 &= \frac{13.4}{9.81 \cdot 4.85^2} \\
 &= 0.58
 \end{aligned}$$

Wave theory : 3rd order stokes wave theory

Zone	Hs	Tp	Depth	g	gt ²	H/gt ²	d/gt ²	Wave Theory
Shore	0,37	4,38	6	9,81	188,199	0,001966	0,031881	Stokes 2
Zona I	0,37	4,38	14	9,81	188,199	0,001966	0,074389	Stokes 2
Zona II	0,78	4,85	13,4	9,81	230,7557	0,0033802	0,05807	Stokes 2
Zona III	0,78	4,85	14	9,81	230,7557	0,0033802	0,06067	Stokes 2
Zona IV	1,34	5,28	15,5	9,81	273,4871	0,0048997	0,056675	Stokes 2
Zona V	1,34	5,28	9,6	9,81	273,4871	0,0048997	0,035102	Stokes 2
Zona VI	2,07	5,64	6,1	9,81	312,0522	0,0066335	0,019548	Stokes 3
Zona VII	2,35	5,74	7,6	9,81	323,216	0,0072707	0,023514	Stokes 3
Zona VIII	2,31	5,73	12,4	9,81	322,0907	0,0071719	0,038498	Stokes 3

Calculation of wavelength

$$L_0 = \frac{g T^2}{2\pi}$$

$$L_0 = 36,6951$$

From table of water of finite depth function (Skjelbreia, 1959)

$$d/L_0 = 0,073764$$

$$d/L = 0,116098$$

$$L = 122,79622$$

Zona	d/Lo	H/d	δ (d/L)	ε	L	C
Zona VI	0,037454	0,339344	0,0766244	0,010812	564,17732	100,03144
Zona VII	0,045053	0,309211	0,0857264	0,117264	64,810812	11,291082
Zona VIII	0,073764	0,18629	0,116098	0,10098	122,79622	21,430405

Calculation of Speed of Water Particles on Pipes

$$S = d + y$$

$$k = \frac{2\pi}{L}$$

$$F_1 = \frac{ka}{\sin kd} - (ka)^2 \frac{\cosh^2 kd(1+5 \cos h^2 kd)}{8 \sin h^5 kd}$$

$$F_2 = \frac{3}{4} (ka)^2 \frac{1}{\sin h^4 kd}$$

$$F_3 = \frac{3}{64} (ka)^3 \frac{11-2 \cosh^2 kd}{\sin h^7 kd}$$

$$\mu = C (F_1 \cosh kS \cos \theta + F_2 \cosh 2kS \cos \theta + F_3 \cosh 3kS \cos \theta)$$

S	S/L	$\cosh 2\pi S/L$	$\cosh 4\pi S/L$	$\cosh 6\pi S/L$
15,128	0,026815	1,01421496	1,057322834	1,130486612
15,441	0,238252	2,345982985	7,482870136	0,446100775
24,866	0,202502	1,924718725	6,409143315	0,227472724

F1	F2	F3	u	Ucurr	Uc
0,137	0,05728	0,0158967	21,75442	0,36	22,11442
0,13161	0,04151	0,0084639	7,0361723	0,24	7,276172
0,0798	0,00756	0,0003867	4,3317405	0,17	4,50174

Calculation Hydrodynamic forces

$$F_D = 1/2 \rho C_D D (Us \cos \theta + Uc)^2$$

$$F_D = 398,2623$$

$$F_I = \rho CM \left[\frac{\pi D^2}{4} \right] \left(\frac{dU}{dt} \right)$$

$$F_I = 0,483118$$

$$F_L = 1/2 \rho C_L D (Us \cos \theta + Uc)^2$$

$$F_L = 298,6967$$

Zone	As	FL	FD	FI
Shore	0,114558	102,96341	137,2845	0,075582
Zona I	0,094829	96,76448	129,0193	0,062566
Zona II	0,195312	115,99579	154,6611	0,128861
Zona III	0,19028	114,61512	152,8202	0,125541
Zona IV	0,275969	138,17697	184,236	0,182076
Zona V	0,583856	257,18462	342,9128	0,385211
Zona VI	1,538639	930,7979	1241,064	1,01515
Zona VII	1,346274	780,16625	1040,222	0,888233
Zona VIII	0,732252	298,6967	398,2623	0,483118

Calculation of Lateral And Vertical Stability Analysis

In DNV RP-109 is the lateral static stability as a whole. The general equation of this method is

$$\gamma_{sc} = \frac{(Ws - FL) \cdot \mu}{FD + F_R} \geq 1.0$$

$$\gamma_{sc} = 1,166993 \geq 1.0$$

Table 4.14 Table of Lateral Stability Calculation

Zone	γ_{sc}	comment
Shore	4,100169	OK
Zona I	4,387132	OK
Zona II	3,596381	OK
Zona III	3,64426	OK
Zona IV	2,958458	OK
Zona V	1,415939	OK
Zona VI	1,040352	OK
Zona VII	1,126205	OK
Zona VIII	1,166993	OK

While the analysis of vertical stability using the following equation

$$\gamma_w = \frac{Ws + b}{b} \geq 1.0$$

$$\gamma_w = 1,558663 \geq 1.0$$

Zone	yw	comment
Shore	1,558663	OK
Zona I	1,558663	OK
Zona II	1,558663	OK
Zona III	1,558663	OK
Zona IV	1,558663	OK
Zona V	1,558663	OK
Zona VI	1,558663	OK
Zona VII	1,558663	OK
Zona VIII	1,558663	OK

Analisis of the correlation of types of soil and the stability of subsea pipeline

Soft Clay

- Tcc = 30 mm

Zone	yw	comment	Zone	ysc	comment
Shore	1,46811	OK	Shore	2,3168	OK
Zona I	1,46811	OK	Zona I	2,482	OK
Zona II	1,46811	OK	Zona II	2,0271	OK
Zona III	1,46811	OK	Zona III	2,0547	OK
Zona IV	1,46811	OK	Zona IV	1,6598	OK
Zona V	1,46811	OK	Zona V	0,7709	Need_More_Thckness
Zona VI	1,46811	OK	Zona VI	0,5543	Need_More_Thckness
Zona VII	1,46811	OK	Zona VII	0,6038	Need_More_Thckness
Zona VIII	1,46811	OK	Zona VIII	0,6274	Need_More_Thckness

- Tcc = 34 mm

Zone	yw	comment	Zone	ysc	comment
Shore	1,51248	OK	Shore	2,6475	OK
Zona I	1,51248	OK	Zona I	2,8339	OK
Zona II	1,51248	OK	Zona II	2,3206	OK
Zona III	1,51248	OK	Zona III	2,3518	OK
Zona IV	1,51248	OK	Zona IV	1,9063	OK
Zona V	1,51248	OK	Zona V	0,9033	Need_More_Thickness
Zona VI	1,51248	OK	Zona VI	0,659	Need_More_Thickness
Zona VII	1,51248	OK	Zona VII	0,7149	Need_More_Thickness
Zona VIII	1,51248	OK	Zona VIII	0,7414	Need_More_Thickness

- Tcc = 40 mm

Zone	yw	comment	Zone	ysc	comment
Shore	1,57544	OK	Shore	3,1529	OK
Zona I	1,57544	OK	Zona I	3,3716	OK
Zona II	1,57544	OK	Zona II	2,7693	OK
Zona III	1,57544	OK	Zona III	2,8058	OK
Zona IV	1,57544	OK	Zona IV	2,2829	OK
Zona V	1,57544	OK	Zona V	1,1058	OK
Zona VI	1,57544	OK	Zona VI	0,819	Need_More_Thckness
Zona VII	1,57544	OK	Zona VII	0,8846	Need_More_Thckness
Zona VIII	1,57544	OK	Zona VIII	0,9157	Need_More_Thckness

- Tcc = 50 mm

Zone	yw	comment	Zone	ysc	comment
Shore	1,67163	OK	Shore	4,0201	OK
Zona I	1,67163	OK	Zona I	4,2943	OK
Zona II	1,67163	OK	Zona II	3,539	OK
Zona III	1,67163	OK	Zona III	3,5848	OK
Zona IV	1,67163	OK	Zona IV	2,9292	OK
Zona V	1,67163	OK	Zona V	1,4531	OK
Zona VI	1,67163	OK	Zona VI	1,0936	Need_More_Thckness
Zona VII	1,67163	OK	Zona VII	1,1758	OK
Zona VIII	1,67163	OK	Zona VIII	1,2148	OK

- Tcc = 60 mm

Zone	yw	comment	Zone	ysc	comment
Shore	1,75817	OK	Shore	4,9183	OK
Zona I	1,75817	OK	Zona I	5,2501	OK
Zona II	1,75817	OK	Zona II	4,3363	OK
Zona III	1,75817	OK	Zona III	4,3917	OK
Zona IV	1,75817	OK	Zona IV	3,5986	OK
Zona V	1,75817	OK	Zona V	1,8129	OK
Zona VI	1,75817	OK	Zona VI	1,3779	OK
Zona VII	1,75817	OK	Zona VII	1,4774	OK
Zona VIII	1,75817	OK	Zona VIII	1,5246	OK

Silty sand

- Tcc = 30 mm

Zone	yw	comment	Zone	ysc	comment
Shore	1,4681	OK	Shore	2,979	OK
Zona I	1,4681	OK	Zona I	3,191	OK
Zona II	1,4681	OK	Zona II	2,606	OK
Zona III	1,4681	OK	Zona III	2,642	OK
Zona IV	1,4681	OK	Zona IV	2,134	OK
Zona V	1,4681	OK	Zona V	0,991	Need_More_Thckness
Zona VI	1,4681	OK	Zona VI	0,713	Need_More_Thckness
Zona VII	1,4681	OK	Zona VII	0,776	Need_More_Thckness
Zona VIII	1,4681	OK	Zona VIII	0,839	Need_More_Thckness

- Tcc = 34 mm

Zone	yw	comment	Zone	ysc	comment
Shore	1,5125	OK	Shore	3,404	OK
Zona I	1,5125	OK	Zona I	3,644	OK
Zona II	1,5125	OK	Zona II	2,984	OK
Zona III	1,5125	OK	Zona III	3,024	OK
Zona IV	1,5125	OK	Zona IV	2,451	OK
Zona V	1,5125	OK	Zona V	1,161	OK
Zona VI	1,5125	OK	Zona VI	0,847	Need_More_Thickness
Zona VII	1,5125	OK	Zona VII	0,919	Need_More_Thickness
Zona VIII	1,5125	OK	Zona VIII	0,992	Need_More_Thickness

- Tcc = 40 mm

Zone	yw	comment	Zone	ysc	comment
Shore	1,5754	OK	Shore	4,054	OK
Zona I	1,5754	OK	Zona I	4,335	OK
Zona II	1,5754	OK	Zona II	3,56	OK
Zona III	1,5754	OK	Zona III	3,607	OK
Zona IV	1,5754	OK	Zona IV	2,935	OK
Zona V	1,5754	OK	Zona V	1,422	OK
Zona VI	1,5754	OK	Zona VI	1,053	Need_More_Thckness
Zona VII	1,5754	OK	Zona VII	1,137	OK
Zona VIII	1,5754	OK	Zona VIII	1,225	OK

- Tcc = 50 mm

Zone	yw	comment	Zone	ysc	comment
Shore	1,6716	OK	Shore	5,169	OK
Zona I	1,6716	OK	Zona I	5,521	OK
Zona II	1,6716	OK	Zona II	4,55	OK
Zona III	1,6716	OK	Zona III	4,609	OK
Zona IV	1,6716	OK	Zona IV	3,766	OK
Zona V	1,6716	OK	Zona V	1,868	OK
Zona VI	1,6716	OK	Zona VI	1,406	OK
Zona VII	1,6716	OK	Zona VII	1,512	OK
Zona VIII	1,6716	OK	Zona VIII	1,625	OK

- Tcc = 60 mm

Zone	yw	comment	Zone	ysc	comment
Shore	1,7582	OK	Shore	6,324	OK
Zona I	1,7582	OK	Zona I	6,75	OK
Zona II	1,7582	OK	Zona II	5,575	OK
Zona III	1,7582	OK	Zona III	5,647	OK
Zona IV	1,7582	OK	Zona IV	4,627	OK
Zona V	1,7582	OK	Zona V	2,331	OK
Zona VI	1,7582	OK	Zona VI	1,772	OK
Zona VII	1,7582	OK	Zona VII	1,9	OK
Zona VIII	1,7582	OK	Zona VIII	2,039	OK

Clay

- Tcc = 30 mm

Zone	yw	comment	Zone	ysc	comment
Shore	1,46811	OK	Shore	3,3097	OK
Zona I	1,46811	OK	Zona I	3,5457	OK
Zona II	1,46811	OK	Zona II	2,8959	OK
Zona III	1,46811	OK	Zona III	2,9352	OK
Zona IV	1,46811	OK	Zona IV	2,3712	OK
Zona V	1,46811	OK	Zona V	1,1012	OK
Zona VI	1,46811	OK	Zona VI	0,7919	Need_More_Thckness
Zona VII	1,46811	OK	Zona VII	0,8626	Need_More_Thckness
Zona VIII	1,46811	OK	Zona VIII	0,8962	Need_More_Thckness

- Tcc = 34 mm

Zone	yw	comment	Zone	ysc	comment
Shore	1,51248	OK	Shore	3,7821	OK
Zona I	1,51248	OK	Zona I	4,0484	OK
Zona II	1,51248	OK	Zona II	3,3152	OK
Zona III	1,51248	OK	Zona III	3,3597	OK
Zona IV	1,51248	OK	Zona IV	2,7233	OK
Zona V	1,51248	OK	Zona V	1,2905	OK
Zona VI	1,51248	OK	Zona VI	0,9415	Need_More_Thickness
Zona VII	1,51248	OK	Zona VII	1,0213	Need_More_Thickness
Zona VIII	1,51248	OK	Zona VIII	1,0592	Need_More_Thickness

- Tcc = 40 mm

Zone	yw	comment	Zone	ysc	comment
Shore	1,57544	OK	Shore	4,5041	OK
Zona I	1,57544	OK	Zona I	4,8166	OK
Zona II	1,57544	OK	Zona II	3,9561	OK
Zona III	1,57544	OK	Zona III	4,0082	OK
Zona IV	1,57544	OK	Zona IV	3,2613	OK
Zona V	1,57544	OK	Zona V	1,5796	OK
Zona VI	1,57544	OK	Zona VI	1,17	OK
Zona VII	1,57544	OK	Zona VII	1,2637	OK
Zona VIII	1,57544	OK	Zona VIII	1,3082	OK

- Tcc = 50 mm

Zone	yw	comment	Zone	ysc	comment
Shore	1,67163	OK	Shore	5,7429	OK
Zona I	1,67163	OK	Zona I	6,1348	OK
Zona II	1,67163	OK	Zona II	5,0557	OK
Zona III	1,67163	OK	Zona III	5,1211	OK
Zona IV	1,67163	OK	Zona IV	4,1846	OK
Zona V	1,67163	OK	Zona V	2,0758	OK
Zona VI	1,67163	OK	Zona VI	1,5622	OK
Zona VII	1,67163	OK	Zona VII	1,6797	OK
Zona VIII	1,67163	OK	Zona VIII	1,7355	OK

- Tcc = 60 mm

Zone	yw	comment	Zone	ysc	comment
Shore	1,75817	OK	Shore	7,0262	OK
Zona I	1,75817	OK	Zona I	7,5002	OK
Zona II	1,75817	OK	Zona II	6,1948	OK
Zona III	1,75817	OK	Zona III	6,2739	OK
Zona IV	1,75817	OK	Zona IV	5,1409	OK
Zona V	1,75817	OK	Zona V	2,5898	OK
Zona VI	1,75817	OK	Zona VI	1,9685	OK
Zona VII	1,75817	OK	Zona VII	2,1106	OK
Zona VIII	1,75817	OK	Zona VIII	2,178	OK

The result of analysis of the correlation of types of soil and the stability of subsea pipeline

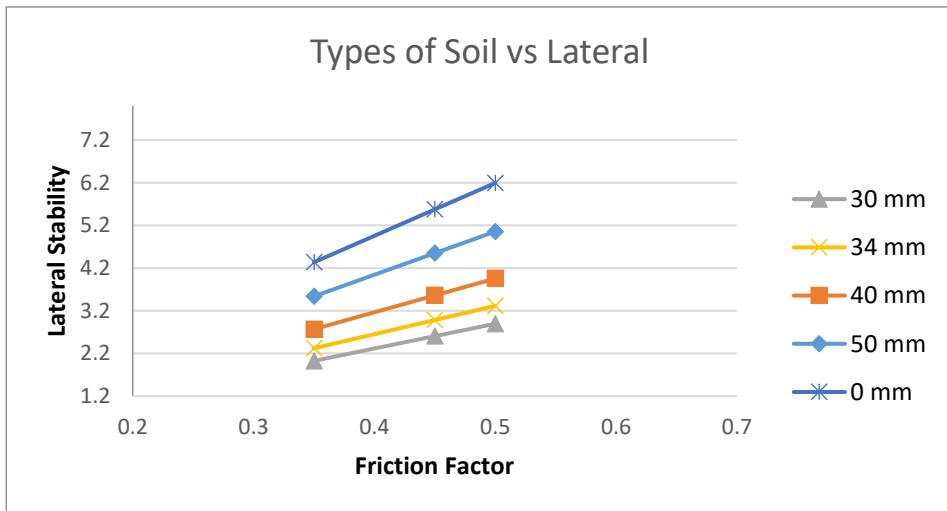
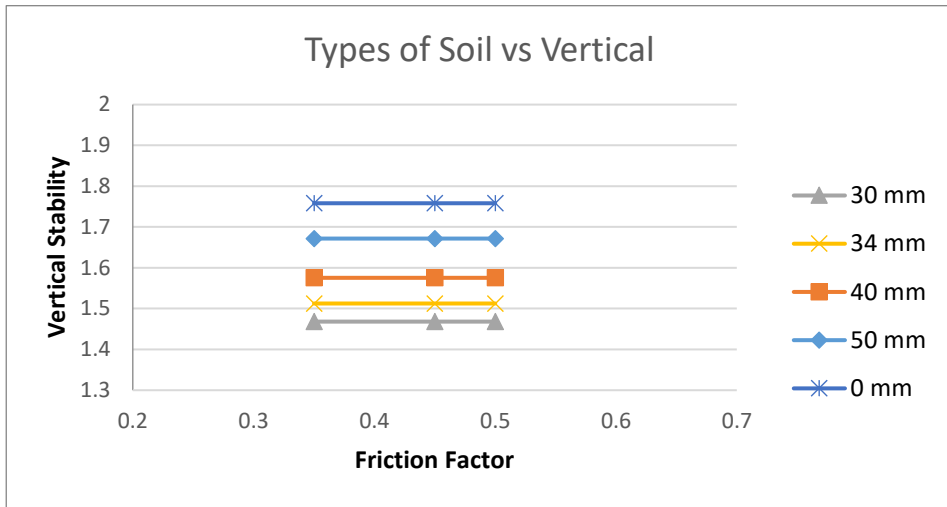

AUTHOR BIOGRAPHY



Akhbar Buddy Al Afghan is student of Marine Engineering Departement (Joint Degree Wismar University of Applied Science, Germany) Faculty of Marine Technology, institute Teknologi Sepuluh Nopember. He was born in Lumajang, East Java on October 04th 1996. During his study in University he was active in several organizations and projects. He took the position as staff of internal Affair Ministry BEM ITS 2016/2018 and head division of political campus of internal Affair Ministry 2018/2019 BEM ITS. Staff of Himpunan Mahasiswa Teknik Sistem Perkapalan 2017, Staff of RBC of Marine icon 2016. He also speaking experience in IPITS 2018. He hold internship certificate in Janata Marina Indah Shipyard, Semarang, Indonesia and PT PGN, Jakarta Indonesia. For further discussion and suggestion regarding this bachelor thesis, the author can be reached through his email: akhbaralafghan@gmail.com.